



Field Charger/Power Supply
HPF24S6 & HPF24S8
HPF24S6E & HPF24S8E
HPF24S6C & HPF24S8C

Fire Alarm System Limitations

An automatic fire alarm system—typically made up of smoke detectors, heat detectors, manual pull stations, audible warning devices, and a fire alarm control panel with remote notification capability—can provide early warning of a developing fire. Such a system, however, does not assure protection against property damage or loss of life resulting from a fire.

The Manufacturer recommends that smoke and/or heat detectors be located throughout a protected premise following the recommendations of the current edition of the National Fire Protection Association Standard 72 (NFPA 72), manufacturer's recommendations, State and local codes, and the recommendations contained in the Guides for Proper Use of System Smoke Detectors, which are made available at no charge to all installing dealers. These documents can be found at <http://www.systemsensor.com/html/applicat.html>. A study by the Federal Emergency Management Agency (an agency of the United States government) indicated that smoke detectors may not go off in as many as 35% of all fires. While fire alarm systems are designed to provide early warning against fire, they do not guarantee warning or protection against fire. A fire alarm system may not provide timely or adequate warning, or simply may not function, for a variety of reasons:

Smoke detectors may not sense fire where smoke cannot reach the detectors such as in chimneys, in or behind walls, on roofs, or on the other side of closed doors. Smoke detectors also may not sense a fire on another level or floor of a building. A second-floor detector, for example, may not sense a first-floor or basement fire.

Particles of combustion or "smoke" from a developing fire may not reach the sensing chambers of smoke detectors because:

- Barriers such as closed or partially closed doors, walls, or chimneys may inhibit particle or smoke flow.
- Smoke particles may become "cold," stratify, and not reach the ceiling or upper walls where detectors are located.
- Smoke particles may be blown away from detectors by air outlets.
- Smoke particles may be drawn into air returns before reaching the detector.

The amount of "smoke" present may be insufficient to alarm smoke detectors. Smoke detectors are designed to alarm at various levels of smoke density. If such density levels are not created by a developing fire at the location of detectors, the detectors will not go into alarm.

Smoke detectors, even when working properly, have sensing limitations. Detectors that have photoelectronic sensing chambers tend to detect smoldering fires better than flaming fires, which have little visible smoke. Detectors that have ionizing-type sensing chambers tend to detect fast-flaming fires better than smoldering fires. Because fires develop in different ways and are often unpredictable in their growth, neither type of detector is necessarily best and a given type of detector may not provide adequate warning of a fire.

Smoke detectors cannot be expected to provide adequate warning of fires caused by arson, children playing with matches (especially in bedrooms), smoking in bed, and violent explosions (caused by escaping gas, improper stor-

While a fire alarm system may lower insurance rates, it is not a substitute for fire insurance!

age of flammable materials, etc.).

Heat detectors do not sense particles of combustion and alarm only when heat on their sensors increases at a predetermined rate or reaches a predetermined level. Rate-of-rise heat detectors may be subject to reduced sensitivity over time. For this reason, the rate-of-rise feature of each detector should be tested at least once per year by a qualified fire protection specialist. *Heat detectors are designed to protect property, not life.*

IMPORTANT! Smoke detectors must be installed in the same room as the control panel and in rooms used by the system for the connection of alarm transmission wiring, communications, signaling, and/or power. If detectors are not so located, a developing fire may damage the alarm system, crippling its ability to report a fire.

Audible warning devices such as bells may not alert people if these devices are located on the other side of closed or partly open doors or are located on another floor of a building. Any warning device may fail to alert people with a disability or those who have recently consumed drugs, alcohol or medication. Please note that:

- Strobes can, under certain circumstances, cause seizures in people with conditions such as epilepsy.
- Studies have shown that certain people, even when they hear a fire alarm signal, do not respond or comprehend the meaning of the signal. It is the property owner's responsibility to conduct fire drills and other training exercise to make people aware of fire alarm signals and instruct them on the proper reaction to alarm signals.
- In rare instances, the sounding of a warning device can cause temporary or permanent hearing loss.

A fire alarm system will not operate without any electrical power. If AC power fails, the system will operate from standby batteries only for a specified time and only if the batteries have been properly maintained and replaced regularly.

Equipment used in the system may not be technically compatible with the control. It is essential to use only equipment listed for service with your control panel.

Telephone lines needed to transmit alarm signals from a premise to a central monitoring station may be out of service or temporarily disabled. For added protection against telephone line failure, backup radio transmission systems are recommended.

The most common cause of fire alarm malfunction is inadequate maintenance. To keep the entire fire alarm system in excellent working order, ongoing maintenance is required per the manufacturer's recommendations, and UL and NFPA standards. At a minimum, the requirements of NFPA 72 shall be followed. Environments with large amounts of dust, dirt or high air velocity require more frequent maintenance. A maintenance agreement should be arranged through the local manufacturer's representative. Maintenance should be scheduled monthly or as required by National and/or local fire codes and should be performed by authorized professional fire alarm installers only. Adequate written records of all inspections should be kept.

Installation Precautions

WARNING - Several different sources of power can be connected to the fire alarm control panel. Disconnect all sources of power before servicing. Control unit and associated equipment may be damaged by removing and/or inserting cards, modules, or interconnecting cables while the unit is energized. Do not attempt to install, service, or operate this unit until this manual is read and understood.

CAUTION - *System Reacceptance Test after Software Changes*. To ensure proper system operation, this product must be tested in accordance with NFPA 72 after any programming operation or change in site-specific software. Reacceptance testing is required after any change, addition or deletion of system components, or after any modification, repair or adjustment to system hardware or wiring.

All components, circuits, system operations, or software functions known to be affected by a change must be 100% tested. In addition, to ensure that other operations are not inadvertently affected, at least 10% of initiating devices that are not directly affected by the change, up to a maximum of 50 devices, must also be tested and proper system operation verified.

This system meets NFPA requirements for indoor dry operation at 0-49° C/32-120° F and at a relative humidity of 93 ±2% RH (non-condensing) at 32 ±2° C/90 ±3° F. However, the useful life of the system's standby batteries and the electronic components may be adversely affected by extreme temperature ranges and humidity. Therefore, it is recommended that this system and all peripherals be installed in an environment with a nominal room temperature of 15-27° C/60-80° F.

Verify that wire sizes are adequate for all initiating and indicating device loops. Refer to manual Specifications section for maximum allowable I.R. drop from the specified device voltage.

Adherence to the following will aid in problem-free installation with long-term reliability:

Like all solid state electronic devices, this system may operate erratically or can be damaged when subjected to lightning-induced transients. Although no system is completely immune from lightning transients and interferences, proper grounding will reduce susceptibility. *Overhead or outside aerial wiring is not recommended, due to an increased susceptibility to nearby lightning strikes.* Consult with the Technical Services Department if any problems are anticipated or encountered.

Disconnect AC power and batteries prior to removing or inserting circuit boards. Failure to do so can damage circuits.

Remove all electronic assemblies prior to any drilling, filing, reaming, or punching of the enclosure. When possible, make all cable entries from the sides or rear. Before making modifications, verify that they will not interfere with battery, transformer, and printed circuit board location.

Do not tighten screw terminals more than 9 in-lbs. Over-tightening may damage threads, resulting in reduced terminal contact pressure and difficulty with screw terminal removal.

This system contains static-sensitive components. Always ground yourself with a proper wrist strap before handling any circuits so that static charges are removed from the body. Use static-suppressive packaging to protect electronic assemblies removed from the unit.

Follow the instructions in the installation, operating, and programming manuals. These instructions must be followed to avoid damage to the control panel and associated equipment. FACP operation and reliability depend upon proper installation by authorized personnel.

FCC Warning

WARNING: This equipment generates, uses, and can radiate radio frequency energy and if not installed and used in accordance with the instruction manual, may cause interference to radio communications. It has been tested and found to comply with the limits for class A computing device pursuant to Subpart B of Part 15 of FCC Rules, which is designed to provide reasonable protection against such interference when operated in a commercial environment. Operation of this equipment in a residential area is likely to cause interference, in which case the user will be required to correct the interference at their own expense.

Canadian Requirements

This digital apparatus does not exceed the Class A limits for radiation noise emissions from digital apparatus set out in the Radio Interference Regulations of the Canadian Department of Communications.

Le présent appareil numérique n'émet pas de bruits radioélectriques dépassant les limites applicables aux appareils numériques de la classe A prescrites dans le Règlement sur le brouillage radioélectrique édicté par le ministère des Communications du Canada.

Table of Contents

System Overview	8
General	8
Features	8
Start-up Procedure	9
Jumpers	10
Jumper JP1 - Ground Fault Detection	10
Jumpers JP2 and JP3: Coded/Noncoded Input Selection	10
LED Indicators	10
Specifications	11
General	13
Installation	14
Backbox Mounting	14
NAC Circuit Wiring	16
Style Y (Class B)	16
ZNAC-4 Class A Option Module	16
Addressable Module Mounting	17
NEC Power-limited Wiring Requirements	18
Programming Options	19
DIP Switch Settings	20
Programmable Features Description	21
Synchronization Type Selection	21
Maximum Number of Strokes for Synchronization	21
Synchronization Mode - Master/Slave	21
AC Fail Delay/Aux. Trouble Relay Function	22
Input/Output Function	22
Auxiliary Power Control	23
Charger Enable/Disable	23
Door Closers	23
Trouble Supervision	24
Supervision via FACP Notification Appliance Circuit	24
Supervision of FACP to HPF24S wiring	24
Supervision of HPF24S Faults	24
Aux. Trouble Relay/AC Fail Relay	25
AC Loss Reporting Delay	25
Applications	26
Controlling Four NACs With One Input and Selective Silence	26
Controlling Three NACs and One Door Holder With One Input	28
Split Temporal Mode of Operation	30
Remote Supply With Resettable and Nonresettable Power	32
Master FACP with Slave HPF24S Power Supply	34
Master HPF24S Power Supply Connected to FACP	35
Canadian Applications	36
Power Supply Requirements	37
Overview	37
Calculating the AC Branch Circuit	37
Calculating the System Current Draw	38
Overview	38
How to Calculate System Current Draw	38
Calculating the Battery Size	40
NFPA Battery Requirements	40
Selecting and Locating Batteries	40
Device Compatibility	41
System Sensor - 24VDC	41
System Sensor SpectrAlert Advance Speakers	42
Gentex - 24VDC 42	

Table of Contents

Cooper-Wheelock - 24VDC43
Notification Appliances For Canadian Applications45
 System Sensor45
 Gentex45
 Cooper-Wheelock45
Wire Requirements46

Notes

It is imperative that the installer understand the requirements of the Authority Having Jurisdiction (AHJ) and be familiar with the standards set forth by the following regulatory agencies:

- Underwriters Laboratories Standards
- NFPA 72 National Fire Alarm Code

Before proceeding, the installer should be familiar with the following documents.



NFPA Standards

NFPA 72 National Fire Alarm Code
NFPA 70 National Electrical Code



Underwriters Laboratories Documents:

UL 464 Audible Signaling Appliances
UL 864 Standard for Control Units for Fire Protective Signaling Systems
UL 1638 Visual Signaling Appliances
UL 1971 Signaling Devices for Hearing Impaired



CAN/ULC - S524-01 Standard for Installation of Fire Alarm Systems
CAN/ULC-S527-99 Standard for Control Units for Fire Alarm Systems

Other:

NEC Article 250 Grounding
NEC Article 300 Wiring Methods
NEC Article 760 Fire Protective Signaling Systems
Applicable Local and State Building Codes
Requirements of the Local Authority Having Jurisdiction (LAHJ)
Canadian Electrical Code, Part 1

This product has been certified to comply with the requirements in the Standard for Control Units and Accessories for Fire Alarm Systems, UL 864, 9th Edition. Operation of this product with products not tested for UL 864, 9th Edition has not been evaluated. Such operation requires the approval of the local Authority Having Jurisdiction (AHJ).

SECTION 1 System Overview

The HPF24S6 is a 6 amp power supply and the HPF24S8 is an 8 amp power supply. Each HPF24S power supply is a compact, cost-effective, remote power supply and battery charger which provides ADA compatible strobe synchronization. The remote power supplies consist of a filtered 24 VDC output that can be configured to drive four Style Y (Class B) NACs (Notification Appliance Circuits). The four circuits can be configured for Style Z (Class A) with the optional ZNAC-4 Class A converter module. Alternatively, the four output circuits may be configured as 24 VDC resettable or nonresettable power outputs. The input circuits, which control the power supply operation, are triggered by the reverse polarity of an NAC or by a 12 VDC or 24 VDC power source. The power supplies are compatible with 12 VDC and 24 VDC control panels.

The HPF24S6E and HPF24S8E offer the same features as the HPF24S6 and HPF24S8 respectively but allow connection to 220/240 VAC. Unless otherwise specified, the information in this manual applies to both the 110/120 VAC versions and the 220/240 VAC versions of the power supplies.

The HPF24S6C and HPF24S8C are the Canadian versions which offer the same features as the HPF24S6 and HPF24S8 respectively. Unless otherwise specified, the information in this manual also applies to the Canadian versions of the power supplies.

1.1 General

The HPF24S power supplies can be used as remotely mounted power supplies and battery chargers to power four noncoded or coded NACs. The Main FACP (Fire Alarm Control Panel) NAC(s) is connected to the remote power supply input circuit(s). When the control input circuit activates due to reverse polarity of the NAC from the FACP, the power supply will activate its Notification Appliance Circuits.

During the inactive or nonalarm state, the power supply supervises its NAC field wiring for short and open conditions. AC fail, battery, charger and ground fault troubles will also be monitored by the power supply. If an NAC or power supply fault is detected, the power supply Normally-Closed Trouble contact will open.

If an alarm condition occurs and the NAC is activated, the supervision is disabled and the Notification Appliance Circuit is no longer supervised (except for shorts). Supervision of other power supply faults such as low battery, AC loss, ground fault and battery charger trouble will continue and may be monitored via the Trouble relay contacts.

1.2 Features

- Self-contained in a lockable cabinet
- 24 VDC remote power supply
- Outputs are completely power-limited
- Two optically-isolated input/control circuits, compatible with 12 VDC and 24 VDC control panel NACs
- Four output circuits:
 - ✓ Fully filtered power
 - ✓ Four 24 VDC Style Y (Class B) NACs (special application)
 - ✓ Optional ZNAC-4 Class A converter module for conversion to Style Z NACs
 - ✓ Alternatively, all four circuits may be configured as 24 VDC special application power outputs
 - ✓ Output circuits may be configured as resettable or nonresettable
- NAC Trouble LED - blinks to indicate the number of the circuit in trouble
- Maximum current available for any one output circuit: 3.0 amps

- Maximum total continuous current available:
 - ✓ 4.0 amps for HPF24S6
 - ✓ 6.0 amps for HPF24S8
- Maximum total short term current (one hour maximum):
 - ✓ 6.0 amps for HPF24S6
 - ✓ 8.0 amps for HPF24S8
- Integral supervised battery charger for lead acid batteries only
- Capable of charging 7.0 AH to 18.0 AH (Amp Hour) batteries
- Fully supervised power supply, battery and NACs
- Selectable Strobe Synchronization for NACs [System Sensor, Gentex and Wheelock]
- Coded signal synchronization
- Fixed terminal blocks for field wiring capable of accepting 12 - 22 AWG wire
- Selectable Ground Fault detection by jumper JP1
- Power supply trouble Form-C relay contacts (fail-safe)
- Optional delay of AC loss reporting for 2 hours
- Auxiliary Special Application Power Output for SLC modules (500 mA maximum) with optional reset for 4-wire smoke detectors
- Mounting location for optional addressable control module

1.3 Start-up Procedure

1. Configure the power supply jumpers as described in "Jumpers" on page 10
2. Install the power supply as described in "Installation" on page 14
3. Program the power supply as described in "Programming Options" on page 19
4. Wire the power supply circuits, referring to the options described in "Trouble Supervision" on page 24 and the application examples in "Applications" on page 26
5. Connect primary power source wiring while observing the following:
 - ✓ Make certain that the AC mains circuit breaker is **off** before making any wiring connections between the mains and the power supply
 - ✓ Make certain primary power source is 120 VAC, 60 Hz, 3.2 amps
 - ✓ Run a pair of wires (with ground conductor) from the protected premises main breaker box to TB1 of the power supply main circuit board
 - ✓ Use 14 AWG (1.6 mm O.D.) or heavier gauge wire with 600V insulation
6. Apply power to the power supply using the following procedure:
 - ✓ apply AC power by turning on the AC mains circuit breaker connected to the power supply
 - ✓ connect a properly charged battery to connector JP4 on the power supply main circuit board



1.4 Jumpers



CAUTION! Remove all power (AC & DC) before cutting or moving any jumpers.

1.4.1 Jumper JP1 - Ground Fault Detection

The Ground Detection circuit monitors for zero impedance between the power supply and ground. Jumper JP1 is located in the top right section of the power supply circuit board. Cutting JP1 will disable ground fault detection by the power supply. This should only be done if ground faults are being monitored by a panel connected to the HPF24S power supply.

1.4.2 Jumpers JP2 and JP3: Coded/Noncoded Input Selection

Jumpers JP2 and JP3 are located in the top right section of the power supply circuit board. JP2 is used for Control Input Circuit #1 and JP3 is used for Control Input Circuit #2. The position of these jumpers will depend on the type of signal being fed to the input circuits:

- If the source voltage to the input circuit is a noncoded (steady voltage) input signal, the jumper for the corresponding input circuit should be in the default position which jumpers the bottom two pins (as illustrated in drawing at left).
- If the source voltage to the input circuit is coded (variable voltage), the jumper for the corresponding input circuit should be moved to jumper the top two pins.

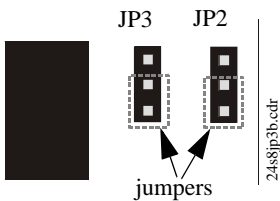

Jumper positions shown for noncoded (steady) source voltage

1.5 LED Indicators

- AC Power on (green) LED - indicates AC power is present
- Ground Fault (yellow) LED - indicates a ground fault condition (zero impedance to ground)
- Battery Trouble (yellow) LED - indicates low or no battery
- NAC Trouble (yellow) LED - indicates a Notification Appliance Circuit trouble (blinks once for Circuit 1 trouble, twice for Circuit 2 trouble, three times for Circuit 3 trouble and four times for Circuit 4 trouble. Note that multiple circuits in trouble will cause the LED to blink the number of the circuit with the highest number)
- ChargerTrouble/AC Loss (yellow) LED - indicates a charger fault or loss of AC power
 - ✓ If AC is applied to the power supply without a battery connected, both the Charger Trouble/AC Loss LED and Battery Trouble LED will turn on simultaneously, indicating that a battery is not connected.
 - ✓ When a battery is connected and the power supply is in Normal Mode, if the battery voltage drops too low or the battery is disconnected, only the Battery Trouble LED will turn on.
 - ✓ When a battery is connected and the charger develops a problem, only the Charger Trouble/AC Loss LED will turn on.

1.6 Specifications

Refer to Figure 1.1 on page 12 for terminal locations.

Primary AC Power - TB1

- HPF24S6 & HPF24S8: 120 VAC, 60 Hz, 3.2 amps maximum
- HPF24S6E & HPF24S8E: 240 VAC, 50 Hz, 1.6 amps maximum
- Wire size: minimum #14 AWG with 600V insulation

Control Input Circuits - TB4, Terminals 3 (+) & 4 (-) and 7 (+) & 8 (-)

- Trigger Input Voltage: 9 to 32 VDC
- Input Current Draw in Alarm Polarity:
 - ✓ 16 to 32 volts, 2.0 mA maximum per input
 - ✓ 9 to 16 volts, 1.0 mA maximum per input

NAC/Output Circuits - TB2, Terminals 1 (+) & 2 (-), 3 (+) & 4 (-), 5 (+) & 6 (-) and 7 (+) & 8 (-) alarm polarity

- Supervised, Special Application and power-limited
- Voltage Rating: 24 VDC filtered
- Current:
 - ✓ Maximum for any one circuit - 3.0 amps
 - ✓ Maximum total continuous current for all output:
 - HPF24S6 - 4.0 amps
 - HPF24S8 - 6.0 amps
 - ✓ Maximum total short term current (one hour maximum) for all outputs:
 - HPF24S6 - 6.0 amps
 - HPF24S8 - 8.0 amps
- Output Circuit Types:
 - ✓ Four Style Y NACs (require 4.7 K Ω End-of-Line Resistors) or Style Z NACs using the optional ZNAC-4 Class A converter module

OR

 - ✓ Four resettable or nonresettable 24 VDC power outputs
- Refer to "Device Compatibility" on page 41, for listed compatible devices

Trouble Relay Contact Rating - TB5

- Fail-safe Form-C relay (normally energized, transfers with loss of power)
- 5.0 amps @ 24 VDC or 5.0 amps @ 30 VAC

Secondary Power (battery) Charging Circuit - JP4

- Supervised, nonpower-limited
- Supports lead acid type batteries only
- Float Charge Voltage: 27.6 VDC
- Maximum Charge Current: 1.5 A
- Battery fuse (F1) 15A, 32V (Canadian version has a 12A, 32V **nonreplaceable** fuse)
- Maximum Battery Capacity: 18.0 AH
- Minimum Battery Capacity: 7.0 AH
- Power supply draws maximum standby current of 65 mA from batteries

Auxiliary Special Application Power Output - TB4 Terminals 9 (+) & 10 (-)

- Special application power
- Power-limited, nonsupervised
- Voltage Rating: 24 VDC
- Current:
 - ✓ 170 mA maximum with internal 7.0 Amp Hour batteries
 - ✓ 500 mA maximum with external 18.0 Amp Hour batteries

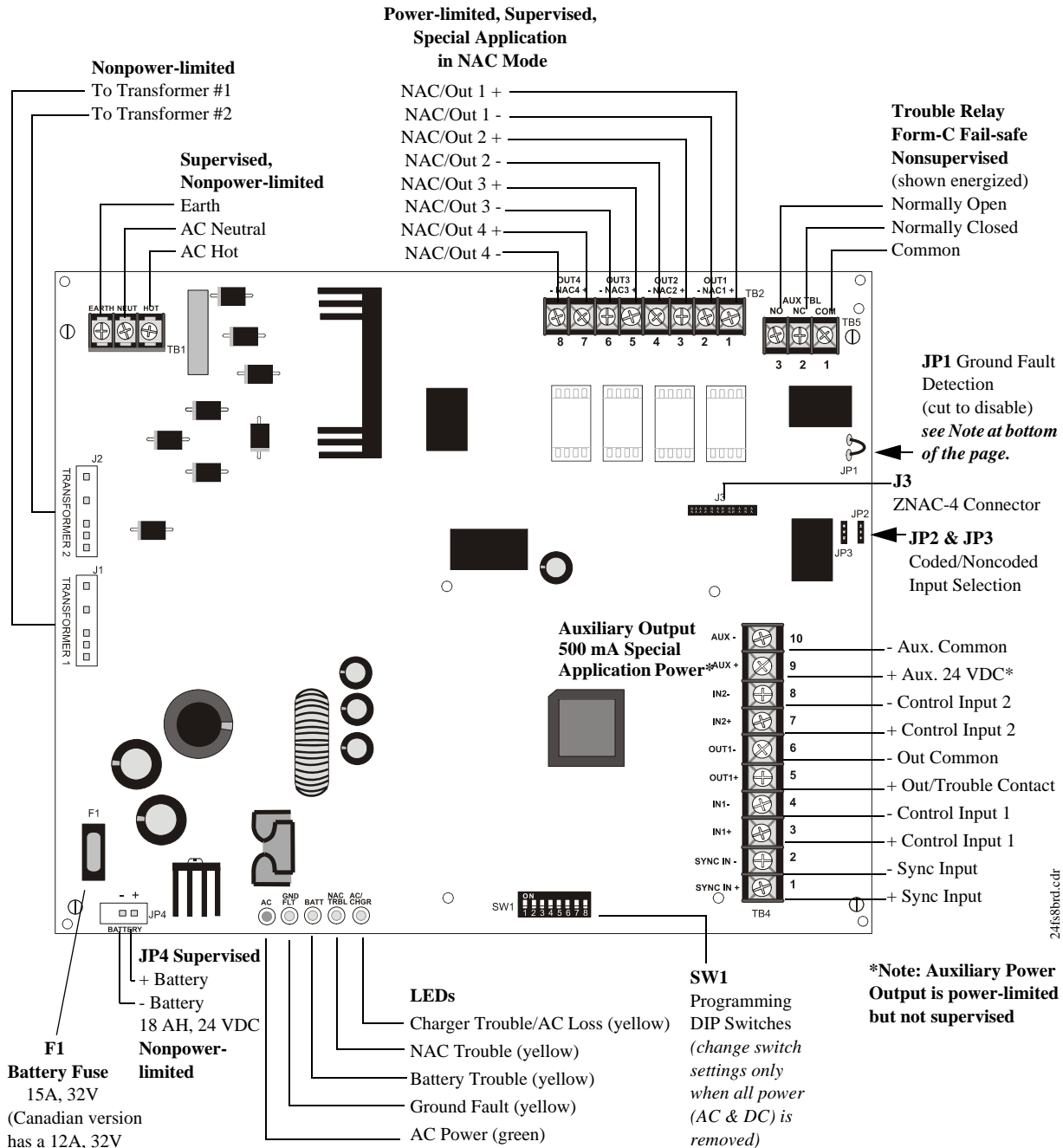

Figure 1.1 HPF24S Board Layout

***Note:** Cutting Ground Fault jumper JP1 voids UL/NFPA Style/Class identifications for circuits unless Ground Faults are being monitored by an FACP connected to the power supply. Cut jumper JP1 only if a panel connected to the power supply is monitoring for Ground Faults or with the approval of AHJ (Authority Having Jurisdiction).*

1.7 General

The HPF24S may be used in a number of different applications. It may be used as a remotely-mounted power supply and battery charger where it can provide up to four coded or noncoded, synchronized or nonsynchronized NACs (Notification Appliance Circuits). Alternatively, output #4 can be used as a door holder circuit which will provide a steady 24 VDC output until an alarm condition or AC fail condition causes it to drop to 0 VDC following a 10 second delay. All four outputs can also provide power.

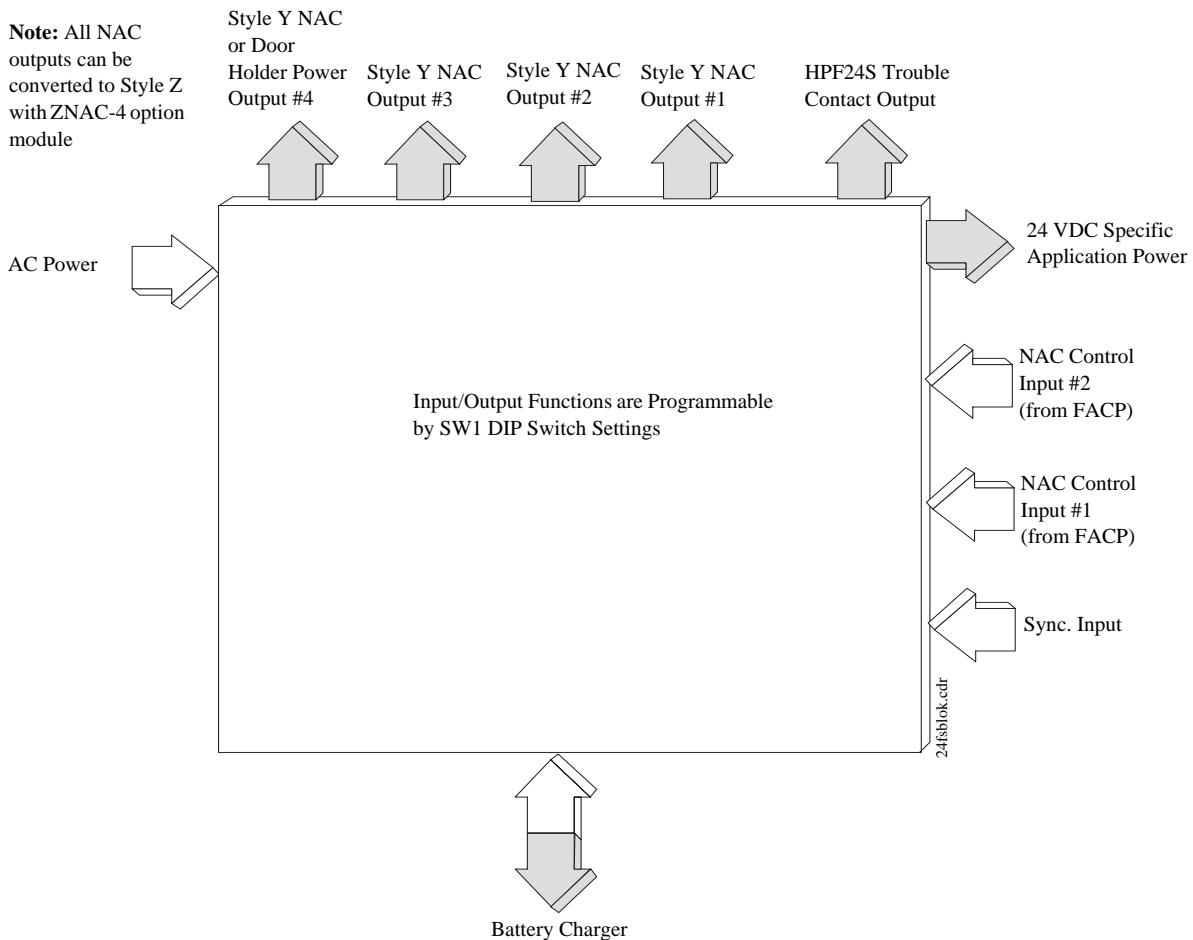

Figure 1.2 Simplified HPF24S Block Diagram

One possible application for the HPF24S remote power supply utilizes the NAC repeater feature. In this application, one or two NACs are connected from the main FACP to the remote power supply control input circuits. When the control input circuits are activated by the reverse polarity of the NACs, the power supply will activate its corresponding output circuits as programmed by SW1 DIP switch configuration (refer to Table 3.1 on page 20).

During the inactive state, the remote power supply supervises its NAC field wiring for short and open conditions. If a fault is detected, the power supply will enter a trouble condition and illuminate the NAC Trouble LED. When the NACs are activated, the supervision is disabled and the circuits are no longer supervised (except for short circuit conditions). Supervision of other power supply faults such as low battery, battery charger trouble, ground fault and AC loss will continue and may be monitored via the power supply trouble relay.

If an application requires that all four outputs activate at the same time, only one NAC is required from the FACP. For this application, the NAC is connected to control input circuit #1 and SW1 DIP switch is set for this operation.

SECTION 2 Installation

Carefully unpack the system and check for shipping damage. Select a location for the cabinet that is in a clean, dry, vibration-free area where extreme temperatures are not encountered. The area should be readily accessible with sufficient room to easily install and maintain the power supply. Locate the top of the cabinet approximately five feet above the floor with the hinge mounting on the left. Determine the number of conductors required for the devices to be installed and determine the appropriate knockouts. All wiring must be in accordance with the National and/or Local codes for fire alarm systems and power supplies.

2.1 Backbox Mounting



The circuit board contains static-sensitive components. Always ground yourself with a proper wrist strap before handling any boards so that static charges are removed from the body. Use static suppressive packaging to protect electronic assemblies.

1. Remove the PC board and transformers from the backbox before installing backbox. Set the board and transformers aside in a safe, clean place. *Avoid static discharge which may damage static sensitive components on the board*
2. Mark and predrill holes for the top two keyhole mounting bolts
3. Install two upper fasteners in the wall with the screw heads protruding approximately 1/4"
4. Using the upper keyholes, mount the backbox over the two screws
5. Mark the lower two holes, remove the backbox from the wall and drill the mounting holes
6. Mount the backbox, install the remaining fasteners and tighten all screws
7. When the location is dry and free of construction dust, reinstall the PC board and transformers and continue with the installation
8. **IMPORTANT!** Make certain to connect the supplied *grounding strap* between the *Earth* terminal on TB1 (AC Terminal Block) of the main circuit board and the *chassis ground stud* as illustrated in Figure 2.1:

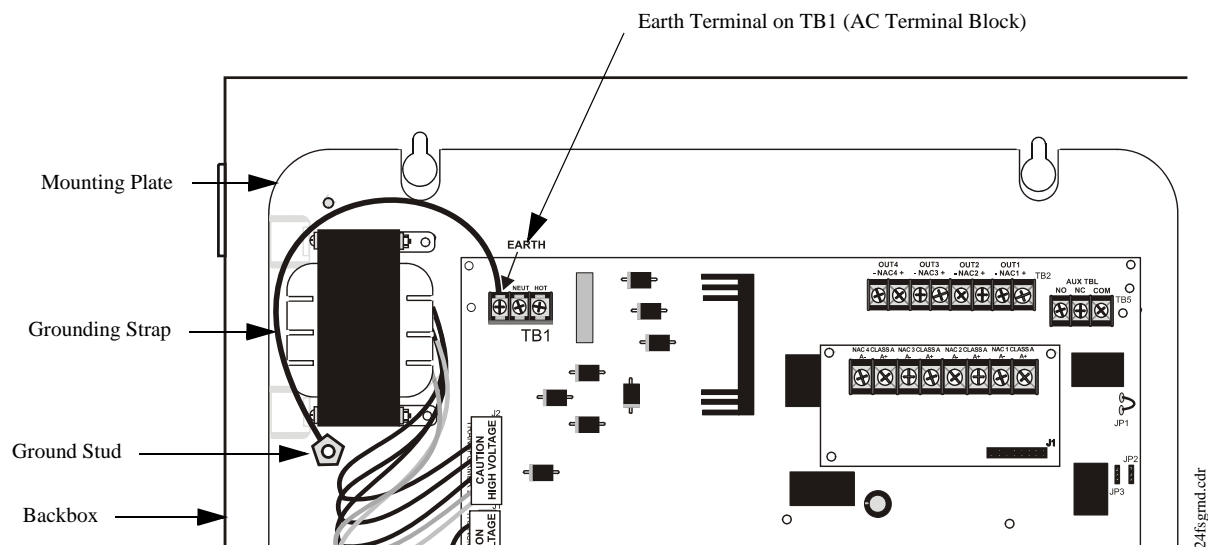

Figure 2.1 Grounding Strap

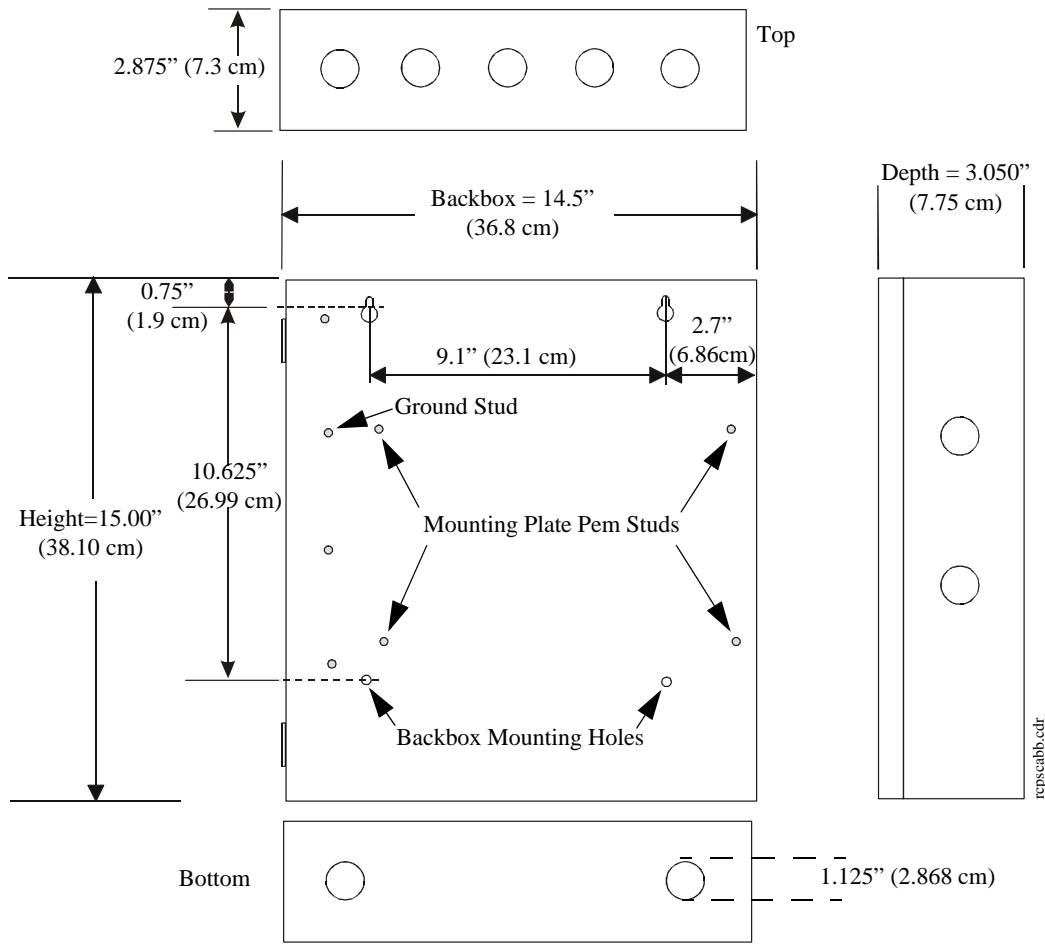

Figure 2.2 Backbox Mounting Dimensions

2.2 NAC Circuit Wiring

2.2.1 Style Y (Class B)

The standard configuration for NACs is Style Y (Class B) as shown in Figure 2.3.

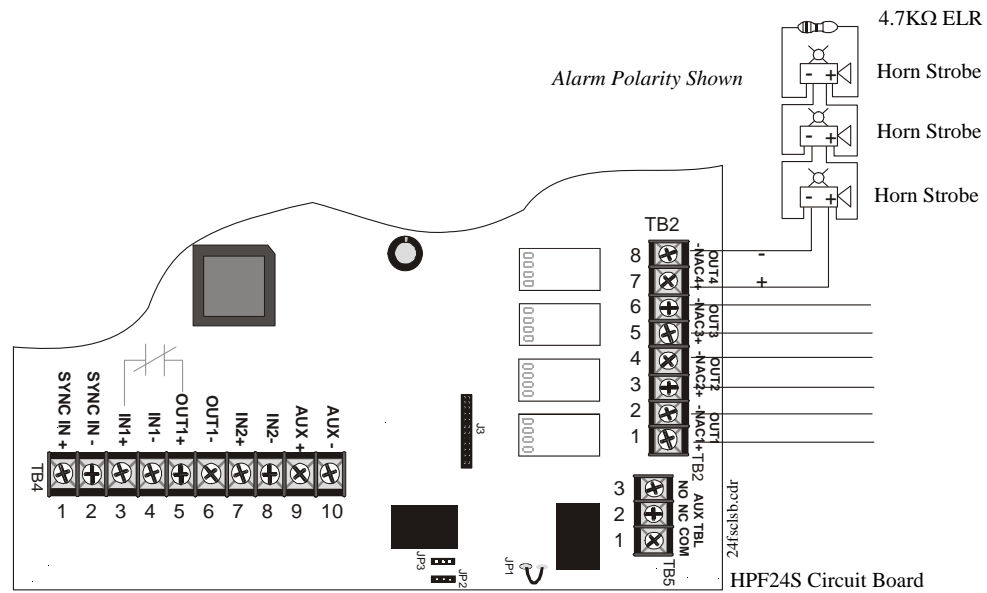

Figure 2.3 NAC Style Y (Class B)

2.2.2 ZNAC-4 Class A Option Module

The ZNAC-4 is an optional Class A conversion module which mounts to connector J3 on the upper right side of the HPF24S circuit board. This module allows the HPF24S6 or HPF24S8 to support Style Z (Class A) Notification Appliance Circuits.

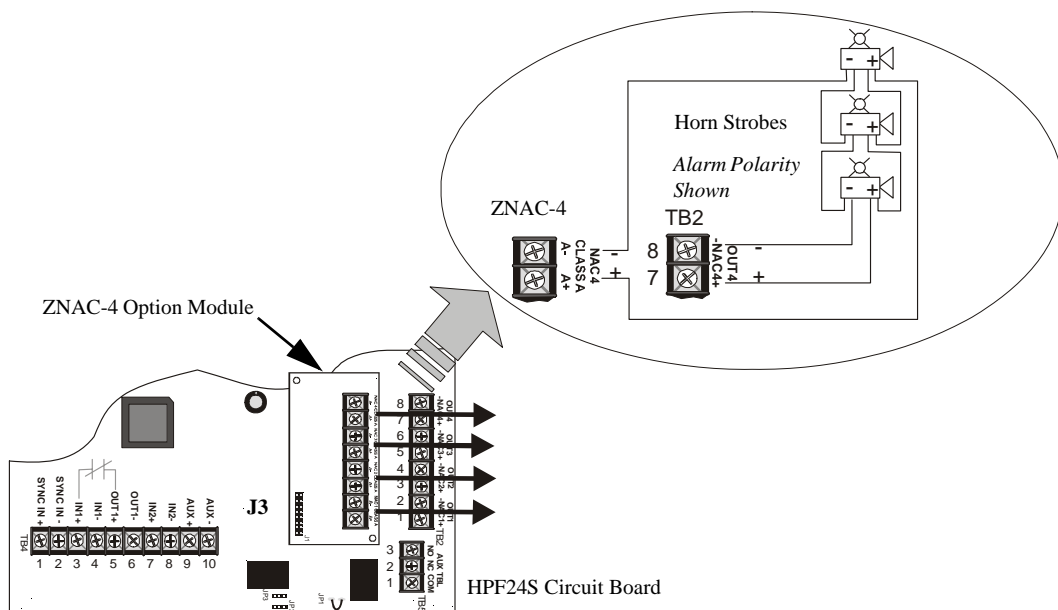
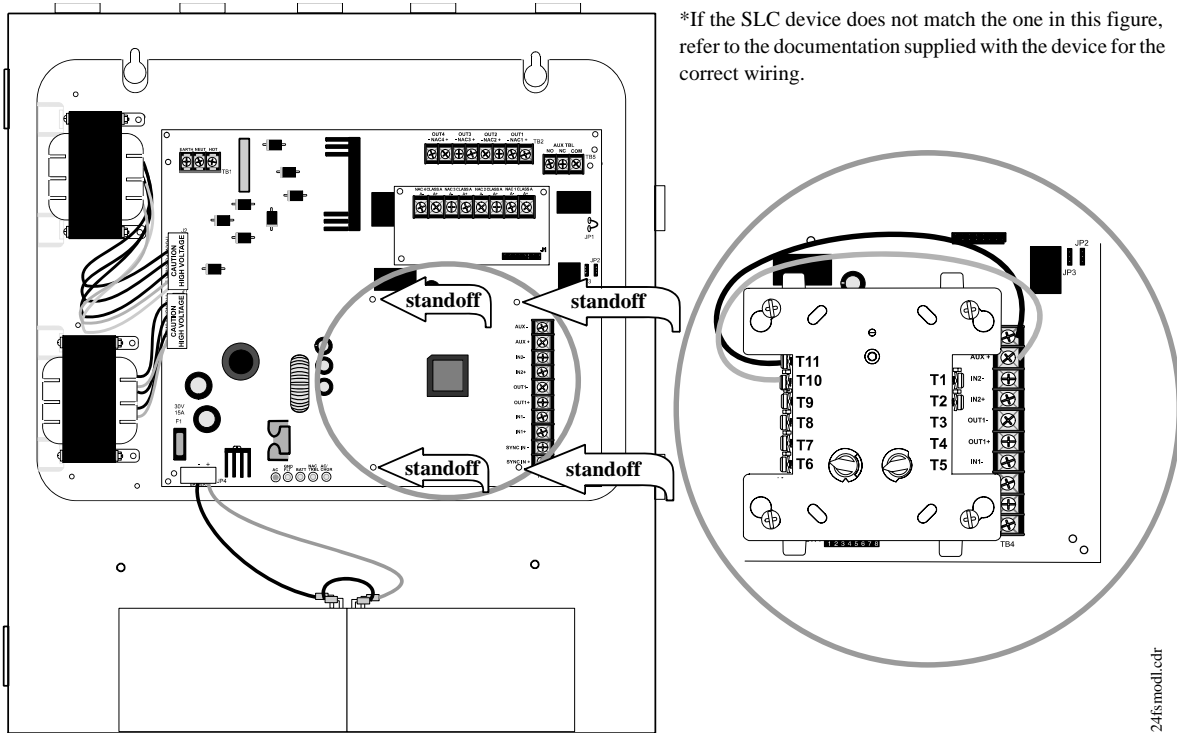

Figure 2.4 Style Z (Class A) NACs using ZNAC-4 Option Module

2.3 Addressable Module Mounting

The HPF24S has been designed to allow the mounting of an addressable control, relay or monitor module on the main circuit board inside the power supply cabinet with the module status LED visible through the closed door. This allows power to be fed from the HPF24S Auxiliary Power output directly to the module, if needed, without running the power wires outside the cabinet. As an example, Figure 2.5 illustrates wiring from the Auxiliary power output terminals to a CMF-300 control module's terminals 3 (-) and 4 (+).

Note that the optional module mounting kit (P/N 90286) is required to install an addressable module on the power supply main circuit board. The kit includes four female/female and four male/female standoffs as well as four mounting screws.



Module Installation

1. Remove HPF24S main circuit board from mounting plate by removing four corner screws.
2. Install four male/female standoffs through bottom of board in holes indicated in illustration above.
3. Screw four female/female standoffs to male ends of standoffs installed in Step 2 to secure in place.
4. Place addressable module over standoffs installed in Step 3 and secure with supplied screws.
5. Reinstall main circuit board on mounting plate and wire module as show in illustration above.

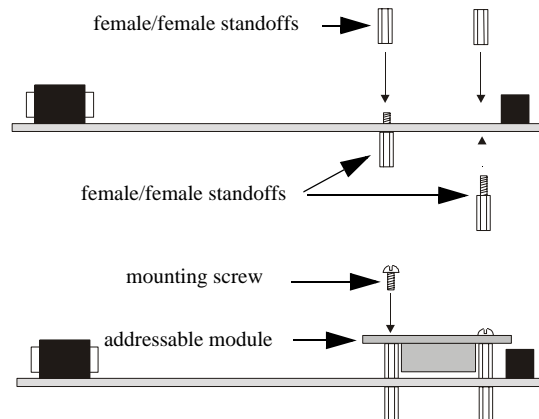

Figure 2.5 Mounting Module In HPF24S Cabinet

2.4 NEC Power-limited Wiring Requirements

Power-limited and nonpower-limited circuit wiring must remain separated in the cabinet. All power-limited circuit wiring must remain at least 0.25” away from any nonpower-limited circuit wiring. Furthermore, all power-limited circuit wiring and nonpower-limited circuit wiring must enter and exit the cabinet through different conduits. One such example of this is shown below. Your specific application may require different conduit knockouts to be used. Any conduit knockouts may be used. For power-limited applications, use of conduit is optional.

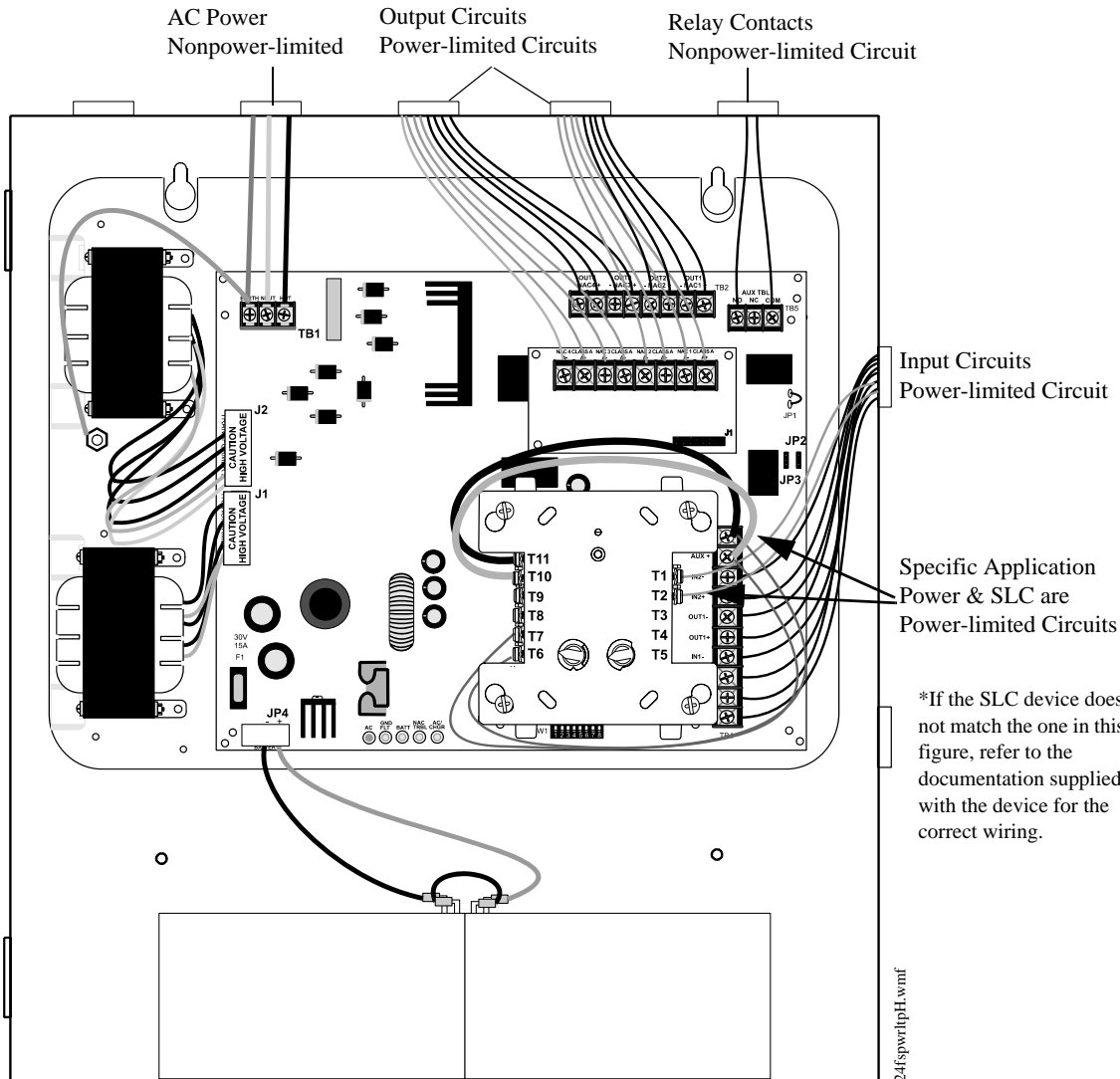

Figure 2.6 Power-limited Wiring Example

SECTION 3 Programming Options

This section describes the programming options available via DIP switch settings. The HPF24S can be field programmed using option DIP switch SW1 which is located in the lower center of the circuit board. Refer to the following illustration for switch location and DIP switch placement in the ON and OFF positions.

Important: Change DIP switch settings only when all power (AC & DC) is removed.

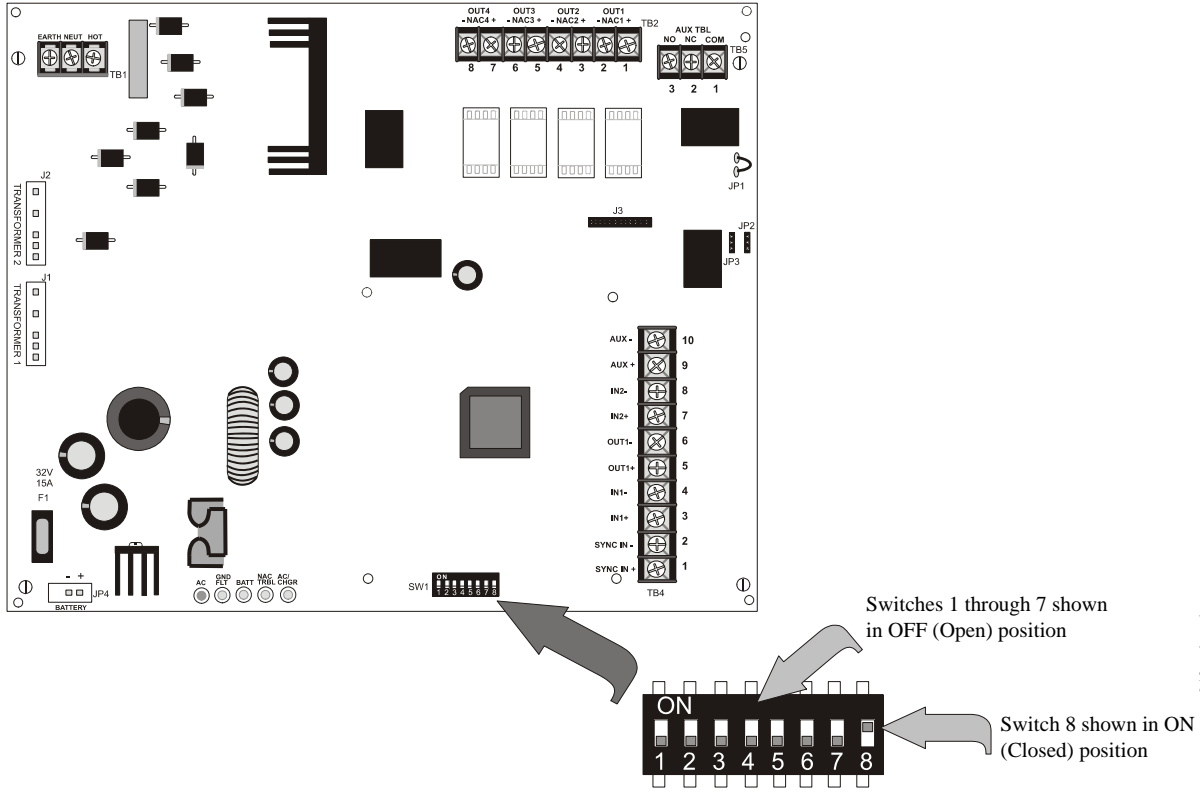

Figure 3.1 Field Programming DIP Switches

3.1 DIP Switch Settings

The following table lists the programmable features and the switch settings required to select a particular feature. A detailed description of each feature is presented in the following pages.

Table 3.1 DIP Switch Settings

SW1 DIP Switch	ON	OFF
1	This switch works in conjunction with switch 2 to determine the Strobe Synchronization Type ¹ .	
2	1 OFF, 2 OFF = no sync (steady +24V) - default 1 OFF, 2 ON = System Sensor 1 ON, 2 OFF = Gentex 1 ON, 2 ON = Wheelock	
3	Supply configured for Slave Synchronization	Supply configured for Master Synchronization - default
4	Delay AC Fail Reporting for 2 Hours - default Aux. Trouble Relay responds to all troubles Internal Trouble contact responds to AC loss	No Delay in AC Fail Reporting Aux. Trouble Relay responds only to AC Fail/Brownout Internal Trouble contact does not respond to AC loss
5	This switch works in conjunction with switch 6 to determine Input to Output functions	
6	5 OFF, 6 OFF = General Alarm - default <ul style="list-style-type: none"> Supply configured as Master (switch 3 OFF), NAC Outputs 1 through 4² are controlled by Control Input #1; Sync Input is ignored. Supply configured as Slave (switch 3 ON), NAC Outputs 1 through 4² are controlled by Control Input #1; Sync Input is monitored³. Resettable or nonresettable Auxiliary Power Output is available from TB4 Terminals 9 & 10. Control Input #2 determines if reset will occur (must go from On to Off for a 6 second reset to occur). Output #4 function follows DIP switch 8 setting. 5 OFF, 6 ON = Split Alarm <ul style="list-style-type: none"> Supply configured as Master (switch 3 OFF), NAC Outputs 1 & 2 are controlled by Control Input #1 and Outputs 3 & 4² are controlled by Control Input #2; Sync Input is ignored. Supply configured as Slave⁵ (switch 3 ON), NAC Outputs 1 & 2 are controlled by Control Input #1 and Outputs 3 & 4² are controlled by Control Input #2; Sync Input is monitored³. Only nonresettable Auxiliary Power is available from TB4 Terminals 9 & 10. Output #4 function follows DIP switch 8 setting. 5 ON, 6 OFF = Split Temporal <ul style="list-style-type: none"> Supply configured as Master (switch 3 OFF), Control Input #1 controls NAC Outputs 1 & 2 and Control Input #2 controls Outputs 3 & 4² which will generate a Temporal code signal without sync; Sync Input is ignored. Supply configured as Slave (switch 3 ON), Control Input #1 controls NAC Outputs 1 & 2 and Control Input #2 controls Outputs 3 & 4² which will generate a Temporal code signal without sync; Sync Input is monitored for Outputs 1 & 2³. Only nonresettable Auxiliary Power is available from TB4 Terminals 9 & 10. Output #4 function follows DIP switch 8 setting. 5 ON, 6 ON = Selective Silence <ul style="list-style-type: none"> Supply configured as Master (switch 3 OFF), NAC Outputs 1 through 4² are controlled by Control Input #1; Sync Input is ignored. Supply configured as Slave (switch 3 ON), NAC Outputs 1 through 4² are controlled by Control Input #1; Sync Input is monitored³. Control Input #2 determines when Selective Silence for all outputs will occur⁴ Only nonresettable Auxiliary Power is available from TB4 Terminals 9 & 10. Output #4 function follows DIP switch 8 setting. 	
7	Disable Charger	Enable Charger - default
8	Output Circuit #4 = Door Holder	Output Circuit #4 = NAC - default
¹ Strobe Synchronization only works with non-coded NACs. ² If Door Closer function is selected (switch 8 ON), Output 4 does not function as an NAC, therefore sync input is ignored for it. ³ If <i>no synchronization</i> is selected by switches 1 & 2, the Sync Input is ignored. ⁴ Selective Silence allows the silencing of the sounder portion of a horn/strobe combination device without turning off the strobe. ⁵ When using Split Alarm with power supply configured for Slave Mode, System Sensor can not be used (use System Sensor with Master Mode only)		

3.2 Programmable Features Description

3.2.1 Synchronization Type Selection

Synchronization is a feature that controls the activation of notification appliances in such a way that all devices will turn on and off at exactly the same time. This is particularly critical when activating strobes which must be synchronized to avoid random activation and a potential hazard or confusion. The HPF24S can be programmed to operate with a variety of manufacturer’s devices. Note that strobe synchronization works only with non-coded NACs.

DIP switches 1 and 2 are used to select the type of synchronization as listed below:

Table 3.2 Sync Type Settings

DIP Switch 1	DIP Switch 2	Synchronization Type
OFF	OFF	no synchronization (steady 24V)
OFF	ON	System Sensor
ON	OFF	Gentex
ON	ON	Wheelock

3.2.1.1 Maximum Number of Strobes for Synchronization

The total current draw for each Notification Appliance Circuit cannot exceed 3.0 amps. Refer to the manufacturer’s documentation supplied with the strobes to determine the maximum current draw for each strobe and ensure that the circuit maximum is not exceeded.

To ensure proper strobe and circuit operation, there is also a limit to the number of strobes that can be attached to each circuit. Following is a table of the strobes that have been tested with the power supply and the maximum number that can be connected to each NAC when using the lowest candela settings. *Make sure that the NAC maximum current is not exceeded:*

Strobe Manufacturer	HPF24S6 (max. strobes)	HPF24S8 (max. strobes)
System Sensor	51	51
Wheelock	30	40
Gentex	39	39

3.2.2 Synchronization Mode - Master/Slave

The HPF24S power supply can be configured for Master or Slave Synchronization by setting DIP switch 3 ON for Slave or OFF for Master mode.

In some installations, it is necessary to synchronize the flash timing of all strobes in the system for ADA compliance. Strobes accomplish this by monitoring very short timing pulses on the NAC power which are created by an FACP. When installed at the end of an FACP NAC wire run, this power supply can track (that is follow) the strobe synchronization timing pulses on the existing NAC wire run. This maintains the overall system flash timing of the additional strobes attached to this power supply.

When this power supply is configured as a *sync generator* (Master Synchronization mode), the Sync Input terminals are not used. The power supply is the originator of the strobe synchronization pulses on its NAC outputs. In *sync generator* mode, the sync type [System Sensor, Wheelock, or Gentex] is selectable via DIP switches 1 and 2.

When this power supply is configured as a *sync follower* (Slave Synchronization mode), the power supply’s NAC outputs track the strobe synchronization pulses present at the supply’s Sync Input terminals. The pulses originate from an upstream FACP or other power supply. Some FACP’s provide synchronization timing pulses from a dedicated sync output connector. Connect the HPF24S sync input terminals to the FACP sync output connector instead of the FACP NAC. *Note that the Synchronization Type configured by DIP switches 1 and 2 must be set to the same type as the signal being fed to the Sync Input circuit in the event that Selective Silence is employed.*

Important! In Slave Mode, if the Input is active, but no signal is present on the Sync Input circuit, the power supply will turn the NACs on steady until a sync signal appears. The NACs will turn off when the Input becomes inactive.

Also in Slave Mode, if the Input is active and the Sync Input is suddenly lost (HPF24S or wiring failure), there will be a three second period when NAC outputs are indeterminate. After this three second period, the power supply will turn the NACs on steady until the Input becomes inactive.

3.2.3 AC Fail Delay/Aux. Trouble Relay Function

The AC Fail Delay feature provides the option to delay generation of a trouble signal upon the loss of AC power. In addition, the operation of the Aux. Trouble Relay is altered.

- DIP switch 4 set to the ON position will delay the generation of an AC Loss/brownout trouble signal for 2 hours. In addition, the Aux. Trouble Relay will immediately respond to all trouble conditions on the power supply.
- DIP switch 4 set to the OFF position will allow the HPF24S to generate a trouble signal immediately on the loss of AC power. In addition, the Aux. Trouble Relay will respond **only** to AC power fail/brownout conditions.

Refer to "Supervision of HPF24S Faults" on page 24, for operation of internal NAC trouble relay in response to AC loss.

3.2.4 Input/Output Function

DIP switches 5 and 6 are used to determine the Input Control circuits that will activate the four output circuits and the function of the output circuits. For example, to configure a **General Alarm** operation in which Input Control Circuit #1 activates all four output NACs, DIP switches 5 and 6 are both set to the OFF position. In this configuration, the Sync Input circuit is ignored if the power supply is set as a Master but will be monitored if the supply is set as a Slave. In addition, if the Auxiliary Power output is set as a resettable output, the circuit connected to Control Input Circuit #2 will control the auxiliary power reset function.

The following table details the four possible input/output configurations:

Table 3.3 Input/Output Configurations

DIP Switch 5	DIP Switch 6	Input/Output Function
OFF	OFF	General Alarm <ul style="list-style-type: none"> • Supply configured as Master (switch 3 OFF), NAC Outputs 1 through 4¹ are controlled by Control Input #1; Sync Input is ignored. • Supply configured as Slave (switch 3 ON), NAC Outputs 1 through 4² are controlled by Control Input #1; Sync Input is monitored². • Resettable or nonresettable Auxiliary Power Output is available from TB4 Terminals 9 & 10. Control Input #2 determines if reset will occur (must go from On to Off for a 6 second reset to occur).
OFF	ON	Split Alarm <ul style="list-style-type: none"> • Supply configured as Master (switch 3 OFF), NAC Outputs 1 & 2 are controlled by Control Input #1 and Outputs 3 & 4¹ are controlled by Control Input #2; Sync Input is ignored. • Supply configured as Slave⁴ (switch 3 ON), NAC Outputs 1 & 2 are controlled by Control Input #1 and Outputs 3 & 4¹ are controlled by Control Input #2; Sync Input is monitored². • Only nonresettable Auxiliary Power is available from TB4 Terminals 9 & 10
ON	OFF	Split Temporal <ul style="list-style-type: none"> • Supply configured as Master (switch 3 OFF), Control Input #1 controls NAC Outputs 1 & 2 and Control Input #2 controls Outputs 3 & 4¹ which will generate a Temporal code signal without sync; Sync Input is ignored. • Supply configured as Slave (switch 3 ON), Control Input #1 controls NAC Outputs 1 & 2 and Control Input #2 controls Outputs 3 & 4¹ which will generate a Temporal code signal without sync; Sync Input is monitored for Outputs 1 & 2². • Only nonresettable Auxiliary Power is available from TB4 Terminals 9 & 10
ON	ON	Selective Silence³ <ul style="list-style-type: none"> • Supply configured as Master (switch 3 OFF), NAC Outputs 1 through 4¹ are controlled by Control Input #1; Sync Input is ignored. • Control Input #2 determines when Selective Silence for all outputs will occur • Only nonresettable Auxiliary Power is available from TB4 Terminals 9 & 10

Table 3.3 Input/Output Configurations

¹ If Door Closer function is selected (switch 8 ON), Output 4 does not function as an NAC, therefore sync input is ignored for Output 4.

² If *no synchronization* is selected by switches 1 & 2, the Sync Input is ignored.

³ Selective Silence allows the silencing of the sounder portion of a horn/strobe combination device without turning off the strobe.

⁴ When using Split Alarm with power supply configured for Slave Mode, System Sensor can not be used (use System Sensor with Master Mode only)

3.2.4.1 Auxiliary Power Control

The 24 VDC Auxiliary power from TB4 Terminals 9(+) & 10(-) can be resettable or nonresettable power only when the power supply is configured for General Alarm operation. For all other configurations, the auxiliary power output is only nonresettable.

In the General Alarm configuration, the Auxiliary power output can be made resettable by applying a steady signal to Control Input 2 (positive 12 to 24 VDC on TB4 Terminal 7 and common on Terminal 8). Temporarily removing the voltage or reversing the polarity will cause the Auxiliary power output to reset for 6 seconds.

3.2.5 Charger Enable/Disable

The HPF24S battery charger can be disabled to accommodate an external battery charger. Setting DIP switch 7 to the default setting of OFF will enable the battery charger. Setting DIP switch 7 to the ON position will disable the charger. It should only be disabled if an external battery charger is being used for the HPF24S.

3.2.6 Door Closers

Output Circuit #4 can be configured as an NAC or door closer circuit. Setting DIP switch 8 to the OFF position will configure Output Circuit #4 as an NAC. Setting DIP switch 8 to the ON position will configure only Output Circuit #4 as a door closer circuit which will provide a steady 24 VDC to door holders until an alarm or AC fail condition removes the power following a 10 second delay.

SECTION 4 Trouble Supervision

4.1 Supervision via FACP Notification Appliance Circuit

4.1.1 Supervision of FACP to HPF24S wiring

The FACP (Fire Alarm Control Panel) supervises the connection between itself and the HPF24S via the control panels NAC End-of-Line Resistor (ELR). The ELR must be installed at the HPF24S end of the circuit, after the last notification appliance on the circuit. If no additional devices are connected from the HPF24S Control Input terminals, the ELR must be connected across terminals 5 & 6 for Control Input Circuit #1 and across terminals 7 & 8 for Control Input Circuit #2. An open or short anywhere on the control panel's NAC or power supply NAC will be detected at the FACP as an NAC trouble.

IMPORTANT: *If additional notification appliances are connected to the Out terminals 5 & 6 of Control Input Circuit #1 or extended from Control Input Circuit #2 Terminals 7 & 8, the ELR must be installed after the last device on the circuit.*

4.1.2 Supervision of HPF24S Faults

The FACP will detect HPF24S power supply faults as an open circuit condition on its NAC. An internal trouble contact is located between TB4 Terminal 3 (In+) and TB4 Terminal 5 (Out+). Any of the following conditions will cause the trouble contact to open, provided the FACP Notification Appliance Circuit is not in alarm. The following trouble conditions will cause a general NAC trouble:

- A field wiring fault on the NAC output of the power supply
- An AC fail condition at the power supply (**only** if SW1 switch 4 is ON and a 2 hour delay has expired. If SW1 switch 4 is OFF, the Internal Trouble contact will not respond to an AC fail condition)
- A battery fail condition at the power supply
- A battery charger fail on the power supply
- A ground fault condition on the power supply (zero impedance between power supply and ground)

Any power supply trouble will break the connection between the FACP and the ELR connected to Control Input #1 provided the FACP's NAC is not in alarm. The FACP's ELR must be placed after the last notification appliance connected to HPF24S terminals 5 & 6 on TB4 or, if no devices are connected to these terminals, the ELR must be connected directly across terminals 5 & 6.

If trouble monitoring is required when the power supply is in alarm, the Trouble Relay at TB5 can be used for this purpose. An addressable monitor module may be used to monitor these contacts. Refer to "Aux. Trouble Relay/AC Fail Relay" on page 25 in the following section.

Note: Control Input #2 (terminals 7 & 8) cannot be used to supervise the power supply for internal troubles, but an ELR is still required for FACP wiring supervision.

4.1.3 Aux. Trouble Relay/AC Fail Relay

The HPF24S power supply has one fail-safe Form-C aux. trouble relay located at TB5. The contacts can be monitored by an FACP input circuit or an addressable monitor module as illustrated below. The Aux. Trouble Relay responds to HPF24S power supply troubles depending on the setting of SW1 switch 4.

- With SW1 switch 4 set to the ON position, AC Fail/brownout reporting will be delayed 2 hours and the following trouble conditions will cause the normally energized Aux. Trouble Relay to change states regardless of whether the panel is in alarm or standby:
 - ✓ An AC fail condition at the power supply
 - ✓ A battery fail condition at the power supply
 - ✓ A battery charger fail on the power supply
 - ✓ A ground fault condition on the power supply (zero impedance between the power supply and ground)
 - ✓ A field wiring fault on the NAC output of the power supply. (If the panel is in alarm, only a short circuit on the NAC will be detected as a trouble)

Note: the NAC Trouble LED will indicate which NAC circuit is in trouble by blinking once for Circuit 1, twice for Circuit 2, three times for Circuit 3 and four times for Circuit 4. If more than one circuit is in trouble, the LED will blink the highest circuit number in trouble.
- With SW1 switch 4 set to the OFF position, AC Fail/brownout reporting will occur immediately and the Aux. Trouble Relay will change state **only** for AC Fail/brownout conditions. A monitor module can be used to monitor the relay for AC fail.

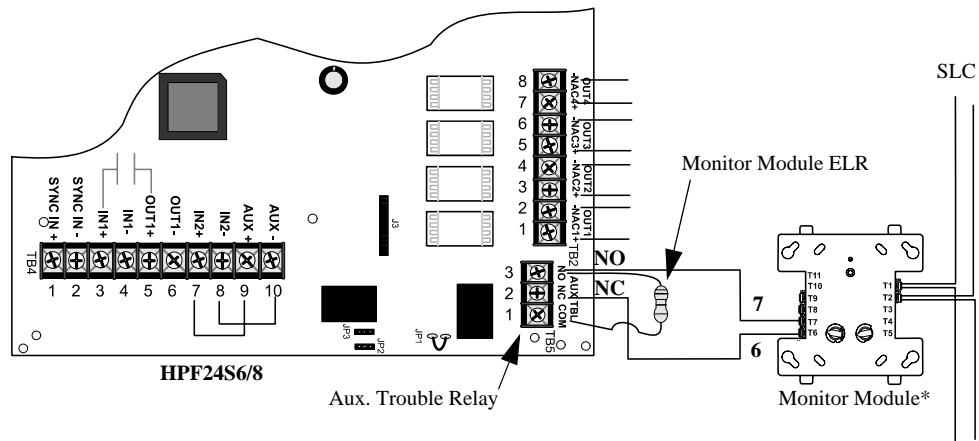

*If the SLC device does not match the one in this figure, refer to the documentation supplied with the device for the correct wiring.

4.2 AC Loss Reporting Delay

The reporting of AC loss to a central station is usually delayed in order to prevent multiple transmissions of AC loss and restoral, thus allowing AC power to stabilize. When a host FACP is programmed to delay AC loss reporting, the HPF24S must be configured to delay the reporting of AC fail. This is accomplished by setting SW1 DIP switch 4 to the ON position. This will prevent AC loss from being reported as a trouble condition for two hours.

Changing the AC Loss Reporting setting will also affect the functioning of the Trouble Relay. Refer to "Aux. Trouble Relay/AC Fail Relay" on page 25.

Note that the HPF24S power supply will immediately indicate loss of AC power by turning off the AC Power LED and turning on the Charger Trouble/AC Loss LED, regardless of the setting of SW1 DIP switch 4.

SECTION 5 Applications

5.1 Controlling Four NACs With One Input and Selective Silence

Note: The Relay Module is required only for this application with the power supply set as Master. If the power supply is set as Slave, the Relay Module is not required. In Slave mode, selective silence (horn mute) is provided by the FACP through the sync input.

In this application, the power supply has been set as a master with synchronized outputs and selective silence (see SW1 switch settings in following illustration). All four HPF24S output circuits, which are shown as NACs (Notification Appliance Circuits), can be controlled from one input such as an addressable control module as illustrated in Figure 5.1. The control module can be powered from the HPF24S auxiliary 24 VDC power output (TB4, Terminals 9 & 10) and supervised by an EOL relay. An addressable relay module, *programmed as an alarm output and a silenceable point*, can be used as a selective silence input.

The control module is shown to demonstrate the use of a remotely mounted device associated with an addressable fire alarm control panel. The module could be replaced with any circuit capable of polarity reversal, such as an FACP NAC.

Note: All NACs are supervised and power-limited

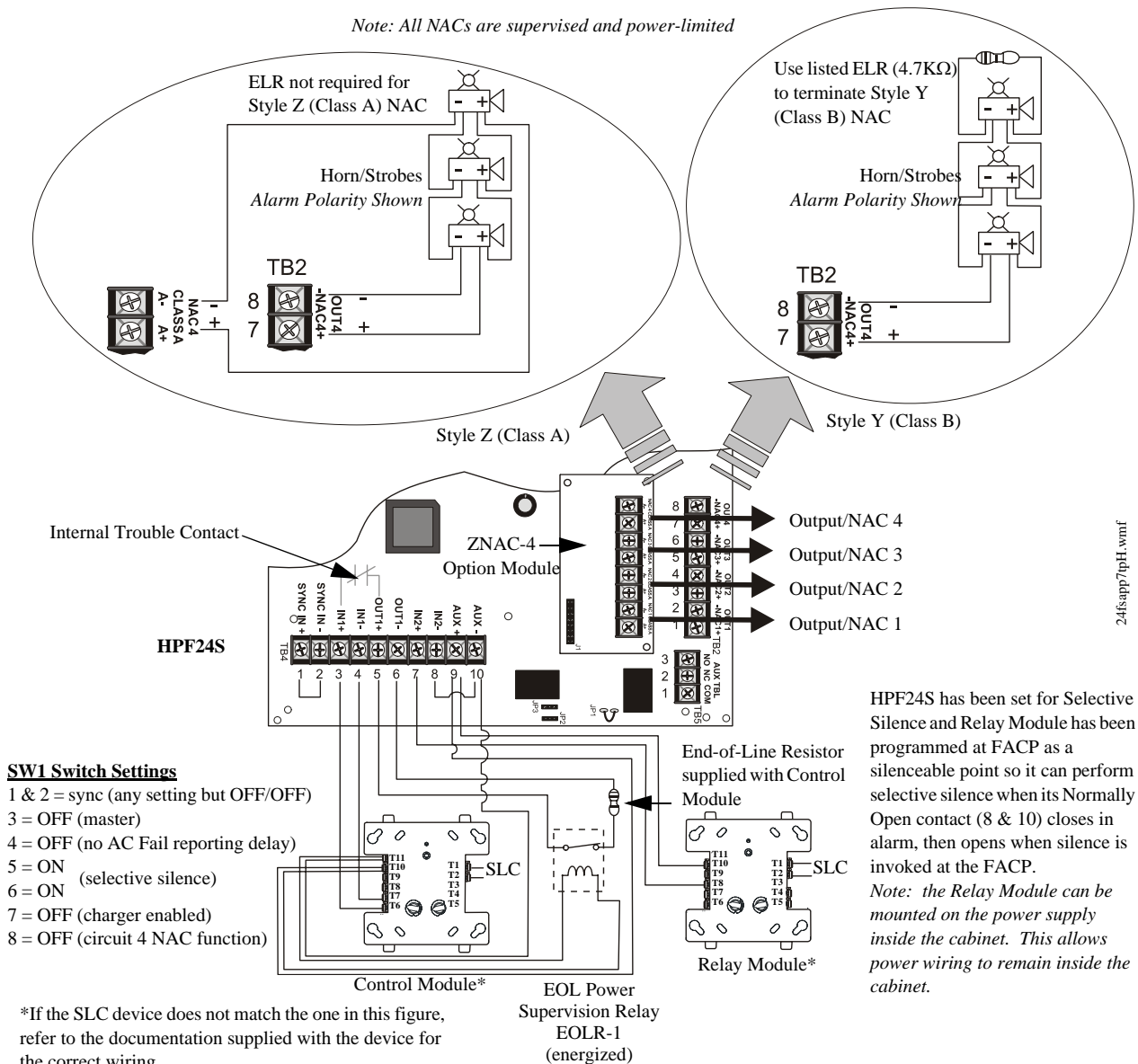
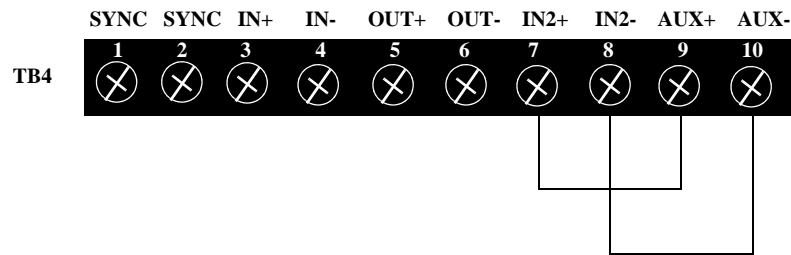

Figure 5.1 Controlling Four Outputs With One Input

Notes: The following notes apply to Figure 5.1 on page 26.

1. When the HPF24S power supply is in an inactive state (control module not active), a trouble on the power supply will result in an open circuit condition on the control module output circuit (monitored by End-of-Line Resistor across TB4, Terminals 5 & 6). As an alternative, the trouble contacts at TB5 of the power supply can also be used for independent trouble monitoring.
2. The addressable relay module must be programmed as a silenceable point at the FACP to allow selective silence of horn/strobe devices. The Normally Open contact of the relay module is connected between TB4 Terminal 7 (IN2 +) and Terminal 9 (Aux. Power +).
3. Do not loop wires under screw terminals. Break wires to maintain proper supervision.
4. An End-of-Line Resistor must be installed between TB4, Terminals 5 & 6 for control module wiring supervision (the ELR value is dependent on the module employed).
5. Supervise the power wiring between the HPF24S auxiliary 24 VDC output on TB4, Terminals 9 & 10 with an EOL relay (P/N: A77-716B).
6. For a list of compatible devices, refer to "Device Compatibility" on page 41.
7. **IMPORTANT!** When the power supply is programmed for both *Selective Silence* and *Slave Mode*, TB4 Terminal 7 (IN+) must be jumpered to Terminal 9 (AUX+) and Terminal 8 (IN-) must be jumpered to Terminal 10 (AUX-). The FACP will control the Selective Silence feature with this configuration.
If the terminals are not jumpered as indicated, the horn portion of the horn/strobes will be silenced at all times.



5.2 Controlling Three NACs and One Door Holder With One Input

In this application, the power supply has been set as a master with synchronized outputs. All four HPF24S output circuits, three NACs and one door holder, can be controlled from one input such as an addressable control module as illustrated in Figure 5.2. The control module can be powered from the HPF24S auxiliary 24 VDC power output (TB4, Terminals 9 & 10).

The control module is shown to demonstrate the use of a remotely mounted device associated with an addressable fire alarm control panel. The module could be replaced with any circuit capable of polarity reversal, such as an FACP Notification Appliance Circuit.

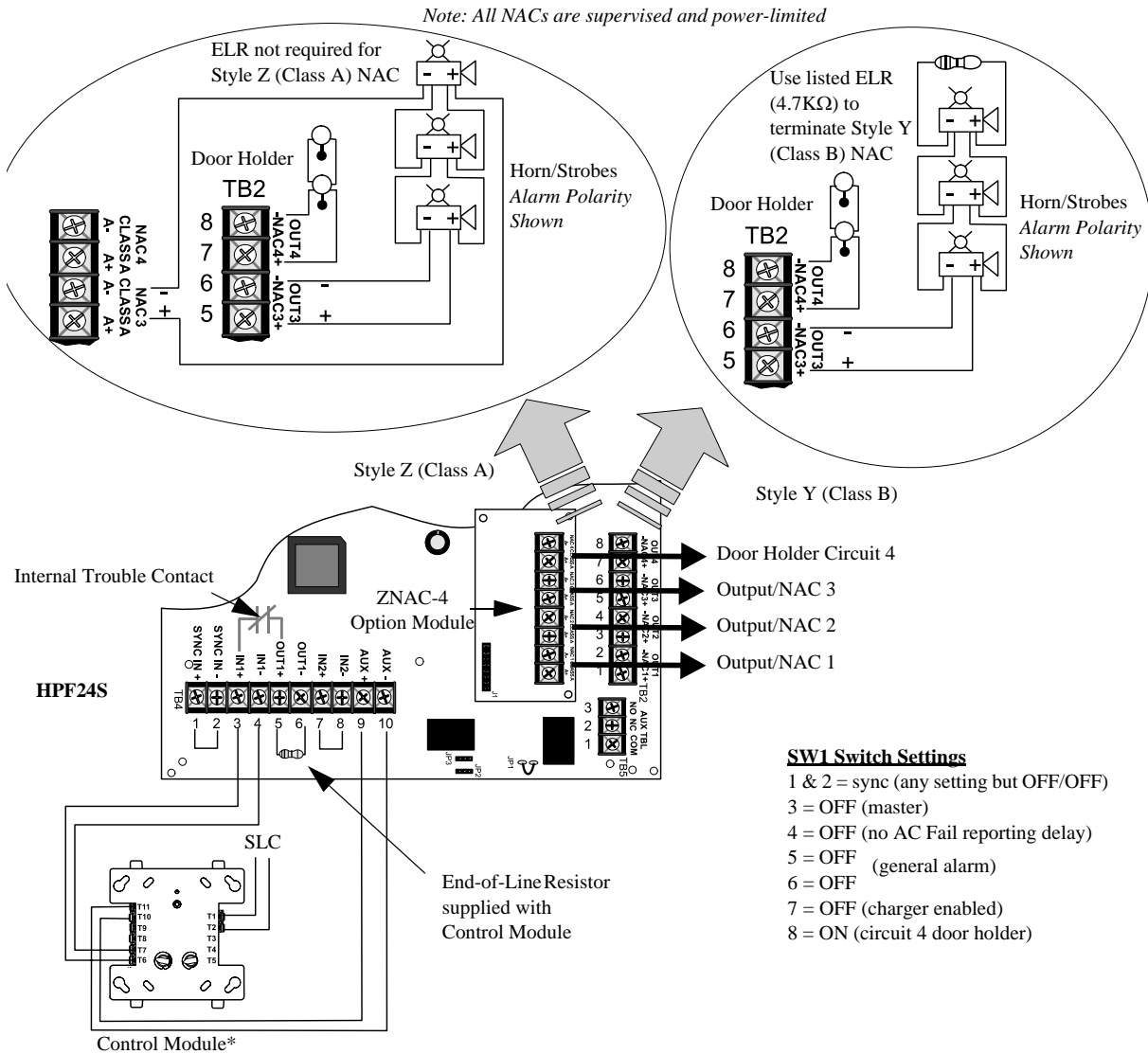

*If the SLC device does not match the one in this figure, refer to the documentation supplied with the device for the correct wiring.

Figure 5.2 Controlling Three NACs and One Door Holder With One Input

Notes: The following notes apply to Figure 5.2 on page 28.

1. The Output 4 door holder circuit will deactivate 10 seconds after Control Input #1 is activated or AC power is lost.
2. When the HPF24S power supply is in an inactive state (control module not active), a trouble on the power supply will result in an open circuit condition on the control module output circuit (monitored by End-of-Line Resistor across Terminals 5 & 6). As an alternative, the trouble contacts at TB5 of the power supply can also be used for independent trouble monitoring.
3. Do not loop wires under screw terminals. Break wires to maintain proper supervision.
4. An End-of-Line Resistor must be installed between terminals 5 & 6 for control module wiring supervision (the ELR value is dependent on the module employed).
5. For a list of compatible devices, refer to "Device Compatibility" on page 41.

5.3 Split Temporal Mode of Operation

In this application, the power supply has been set as a master with two synchronized and two nonsynchronized outputs as determined by the Split Temporal mode feature. Control Input #1 (TB4, Terminals 3 & 4) is connected to an addressable control module which will cause the synchronized power supply output circuits 1 & 2 to turn on. Control Input #2 (TB4, Terminals 7 & 8) is connected to an FACP Notification Appliance Circuit which is used to activate the power supply's temporal output circuits 3 & 4.

Note: All NACs are supervised and power-limited

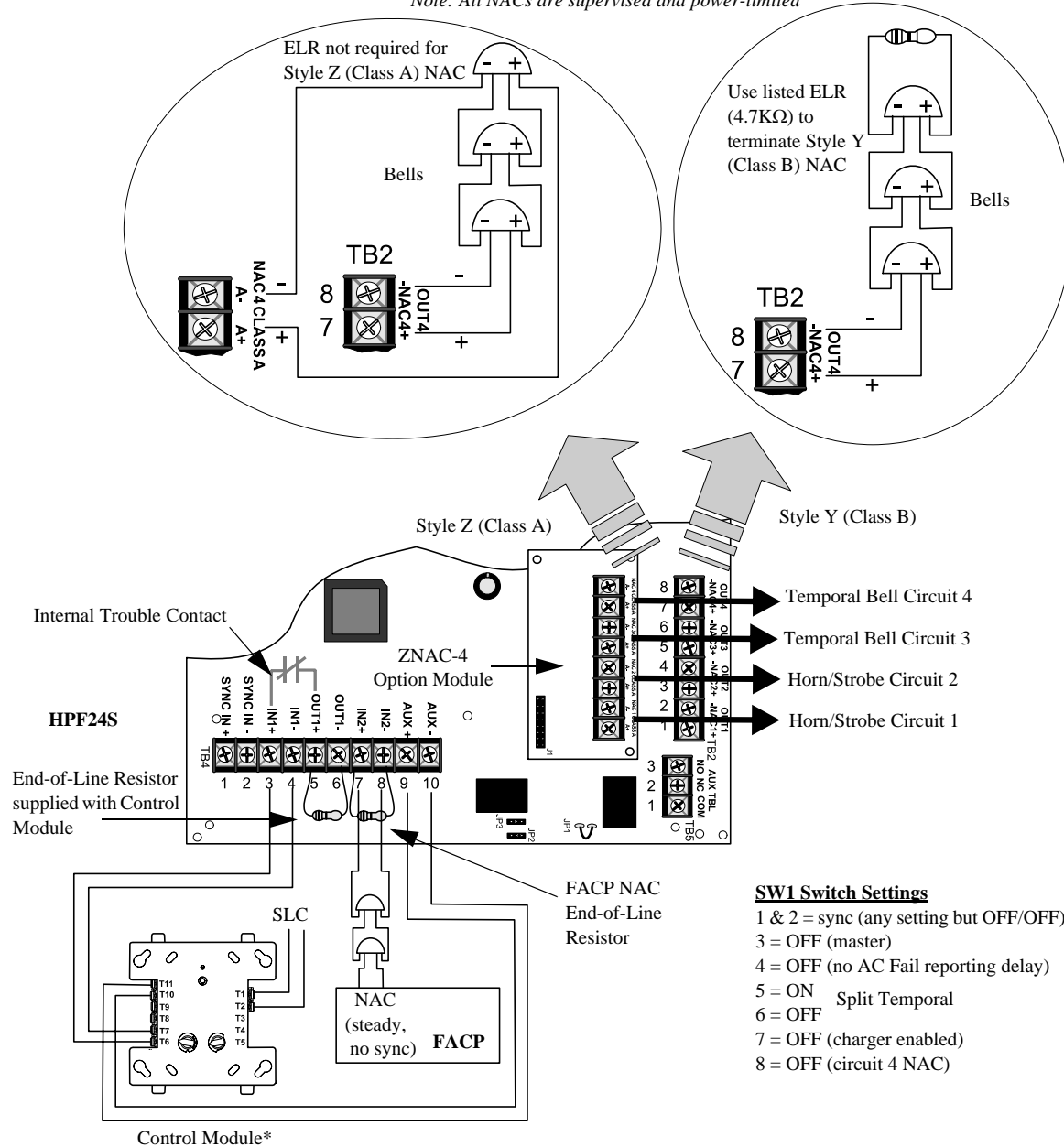

*If the SLC device does not match the one in this figure, refer to the documentation supplied with the device for the correct wiring.

Figure 5.3 Split Temporal Mode Application

Notes: The following notes apply to Figure 5.3 on page 30.

1. When the HPF24S power supply is in an inactive state (control module not active), a trouble on the power supply will result in an open circuit condition on the control module output circuit (monitored by End-of-Line Resistor across Terminals 5 & 6). As an alternative, the trouble contacts at TB5 of the power supply can also be used for independent trouble monitoring.
2. Do not loop wires under screw terminals. Break wires to maintain proper supervision.
3. An End-of-Line Resistor must be installed between terminals 5 & 6 for control module wiring supervision (the ELR value is dependent on the module employed) and across terminals 7 & 8 for FACP NAC wiring supervision (the ELR value is dependent on the NAC).
4. For a list of compatible devices, refer to "Device Compatibility" on page 41.

5.4 Remote Supply With Resettable and Nonresettable Power

The HPF24S can be used as a remote stand-alone power supply to provide power to any devices that require filtered, resettable or nonresettable power. The HPF24S6 can provide up to 4 amps of continuous current and the HPF24S8 can provide up to 6 amps of continuous current. The power supply must be set for Split Alarm mode. Output circuits 1 & 2 are configured as resettable power outputs by connecting the resettable power from an FACP to Control Input 1 Terminals 3(+) & 4(-) on TB4 of the HPF24S. Output circuits 3 & 4 are configured as nonresettable power outputs by connecting jumpers between the auxiliary 24 VDC output on TB4 to the Control Input 2 terminals on TB4 [Terminals 9(+) to 7(+) and 10(-) to 8(-)].

Note: All four outputs can be configured as resettable or all four can be configured as nonresettable by setting the power supply for General Alarm and then connecting a resettable power source to Control Input 1 or a nonresettable power source, such as the Aux. Power output of the HPF24S, to Control Input 1.

For addressable panel applications, an addressable monitor module can be used to monitor the trouble contact of the HPF24S and the resettable power connection from the FACP using an End-of-Line power supervision relay. If the HPF24S enters a trouble condition, the Normally Closed trouble contact will open and if the resettable power from the FACP is lost, the Normally Closed power supervision relay contact will open.

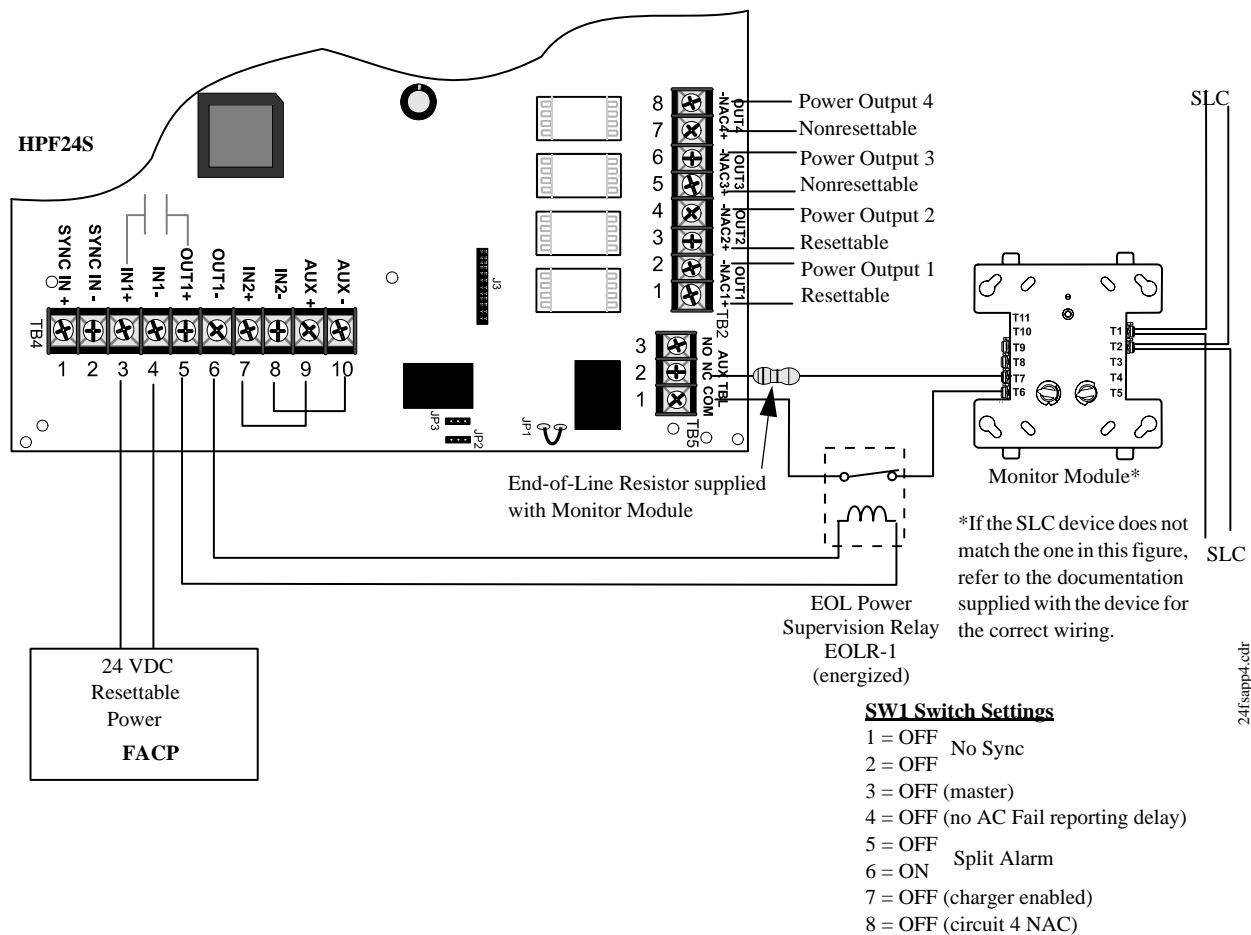

Figure 5.4 Remote Power Supply Application

Notes: The following notes apply to Figure 5.4 on page 32.

1. An End-of-Line Resistor must be installed between TB5, Terminal 1 (trouble relay common) and the monitor module input circuit for module wiring supervision (the ELR value is dependent on the module employed).
2. An End-of-Line power supervision relay must be connected between TB4, Terminals 5 & 6. The Normally Closed (when energized) power supervision relay contact must be in series with the End-of-Line Resistor referred to in note 1.
3. Do not loop wires under screw terminals. Break wires to maintain proper supervision.
4. For a list of compatible devices, refer to "Device Compatibility" on page 41.

5.5 Master FACP with Slave HPF24S Power Supply

In this application, an HPF24S power supply, configured as a Slave unit, is connected to a master FACP NAC programmed for synchronized output. The power supply should be set for synchronization which matches the FACP programming.

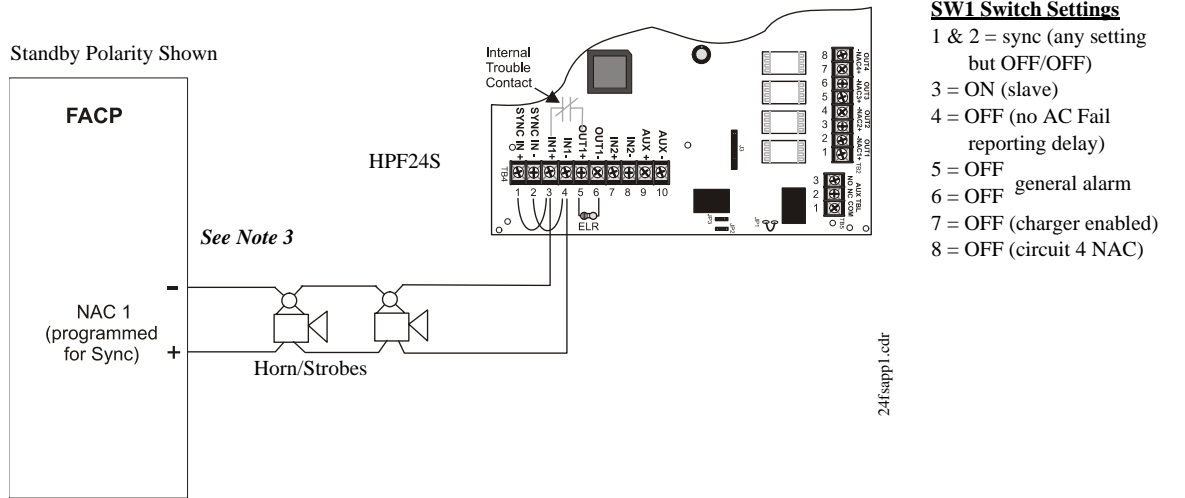

5.6a: Supervised Master/Slave Connections (Filtered, Synchronized NAC Source)

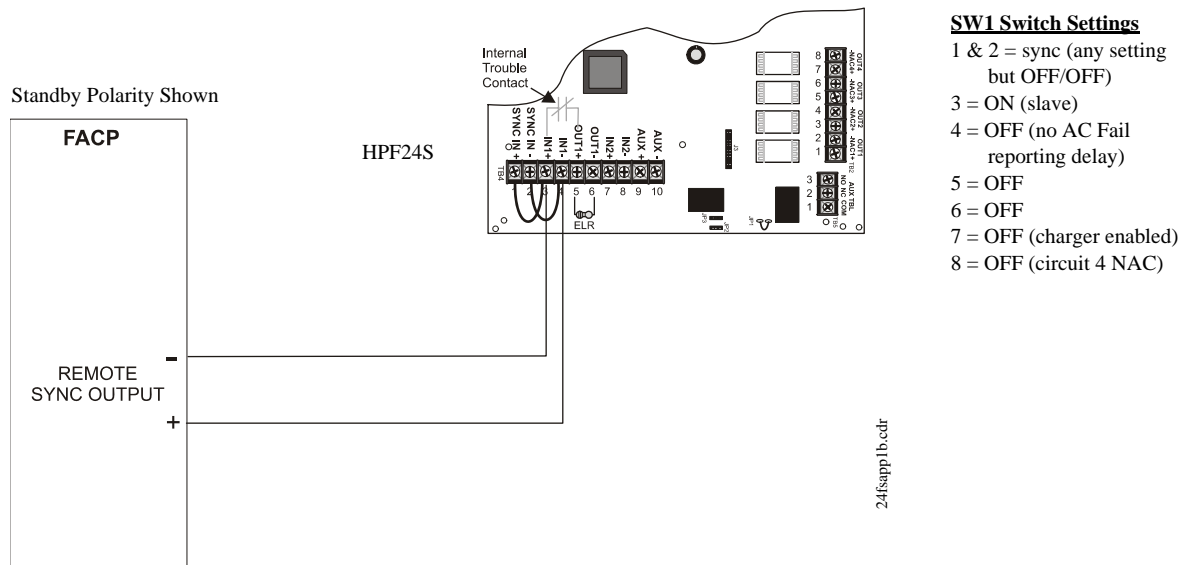

5.6b: Supervised Master/Slave Connections (Remote Sync Source)

Figure 5.5 Supervised Master/Slave Connections

Note: The following notes apply to both illustrations in Figure 5.5

1. Refer to NFPA 72, Chapter 4-4, Visible Characteristics, Public Mode.
2. Use only devices from the same manufacturer in each system.
3. If the FACP has a dedicated sync output connector, wire the remote sync output connector to the HPF24S Sync In terminals TB4 terminals 1 & 2. Refer to the Supervised Master/Slave Connections (Remote Sync Source) in 5.6b.

5.6 Master HPF24S Power Supply Connected to FACP

In this application, a master HPF24S power supply, set for synchronization, is connected to an FACP NAC with nonsynchronized output.

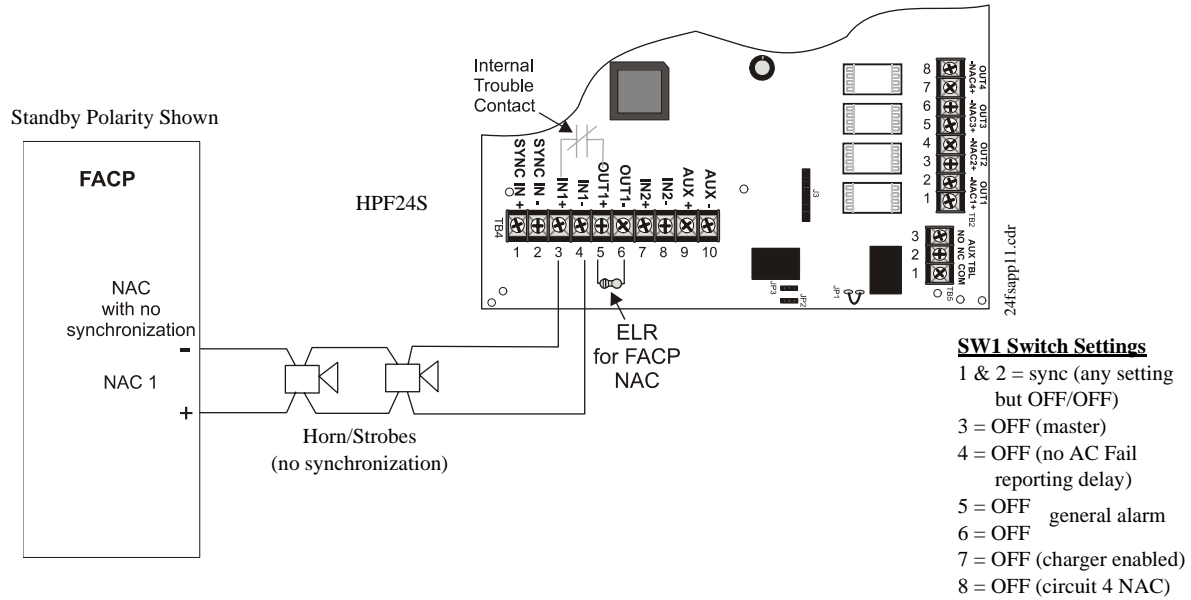

Figure 5.6 Supervised FACP to Master Connections (nonsynchronized source)

Note: The following notes apply to this illustration

1. Refer to NFPA 72, Chapter 4-4, Visible Characteristics, Public Mode.
2. Use only devices from the same manufacturer in each system.

5.7 Canadian Applications

Canadian applications, per ULC, require the following:

- the HPF power supply must be used as a Notification Appliance Circuit extender only. The TB2 terminals cannot be configured as auxiliary power outputs.
- the host FACP must monitor for all ground fault conditions. The Ground Fault Detection circuit on the HPF power supply must be disabled by cutting jumper JP1.
- the negative (-) battery terminal of the HPF power supply must be connected to the negative (-) battery terminal of the host FACP.

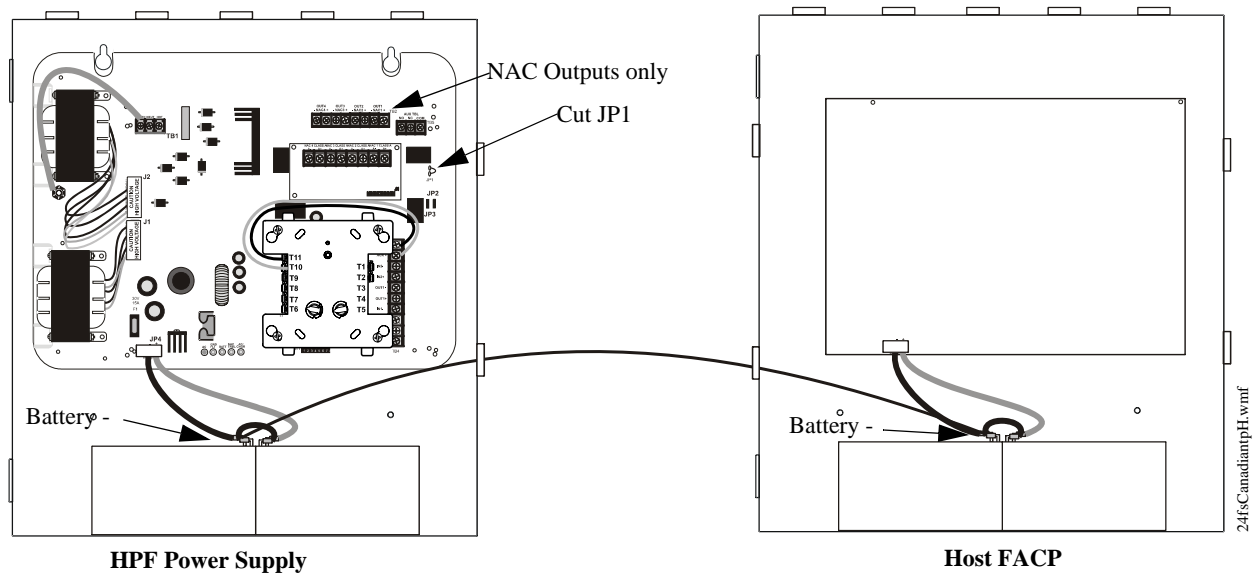

*If the SLC device does not match the one in this figure, refer to the documentation supplied with the device for the correct wiring.

SECTION 6 Power Supply Requirements

6.1 Overview

This section contains instructions and tables for calculating power supply currents in alarm and standby conditions. This is a four-step process, consisting of the following:

1. Calculating the total amount of AC branch circuit current required to operate the system
2. Calculating the power supply load current for non-fire and fire alarm conditions and calculating the secondary (battery) load
3. Calculating the size of batteries required to support the system if an AC power loss occurs
4. Selecting the proper batteries for your system

6.2 Calculating the AC Branch Circuit

The power supply requires connection to a separate, dedicated AC branch circuit, which must be labeled **FIRE ALARM**. This branch circuit must connect to the line side of the main power feed of the protected premises. No other non-fire alarm equipment may be powered from the fire alarm branch circuit. The branch circuit wire must run continuously, without any disconnect devices, from the power source to the power supply. Overcurrent protection for this circuit must comply with Article 760 of the National Electrical Codes as well as local codes. Use 14 AWG (2.00 mm²) wire with 600 volt insulation for this branch circuit.

Use Table 6.1 to determine the total amount of current, in AC amperes, that must be supplied to the system

Table 6.1 120/240 VAC Branch Circuit Requirements

Device Type	Number of Devices		Current Draw (AC amps)		Total Current per Device
HPF24S6/8 or HPF24S6/8E	1	X	3.2 or 1.6	=	
[]	[]	X	[]	=	
[]	[]	X	[]	=	
Sum Column for AC Branch Current Required				=	

6.3 Calculating the System Current Draw

6.3.1 Overview

The power supply must be able to power all internal and external devices continuously during the non-fire alarm condition. To calculate the non-fire alarm load on the power supply when primary power is applied, use Calculation Column 1 in Table 6.3 on page 39. The power supply must support a larger load current during a fire alarm condition. To calculate the fire alarm load on the power supply, use Calculation Column 2 in Table 6.3 on page 39. The secondary power source (batteries) must be able to power the system during a primary power loss. To calculate the non-fire alarm load on the secondary power source, use Calculation Column 3 in Table 6.3 on page 39.

When calculating current draw and the battery size, note the following:

- *Primary* refers to the main power source for the power supply
- *Secondary* refers to the power supply's backup batteries
- All currents are given in amperes (A). Table 6.2 shows how to convert milliamperes and microamperes to full amperes

Table 6.2 Converting to Full Amperes

To convert...	Multiply	Example
Milliamperes (mA) to amperes (A)	mA x 0.001	3 mA x 0.001 = 0.003 A
Microamperes (μA) to amperes (A)	μA x 0.000001	300 μA x 0.000001 = 0.0003 A

6.3.2 How to Calculate System Current Draw

Use Table 6.3 on page 39 to calculate current draws as follows:

1. Enter the quantity of devices in all three columns
2. Enter the current draw where required. Refer to "Device Compatibility" on page 41
3. Calculate the current draws for each in all columns
4. Sum the total current for each column
5. Copy the totals from Column 2 and Column 3 to Table 6.3 on page 39

Following are the types of current that can be entered into Table 6.3 on page 39

- ✓ **Calculation Column 1** - The primary supply current load that the power supply must support during a non-fire alarm condition, with AC power applied
- ✓ **Calculation Column 2** - The primary supply current load the power supply must support during a fire alarm condition, with AC power applied
- ✓ **Calculation Column 3** - The standby current drawn from the batteries in a non-fire alarm condition during a loss of AC power

Table 6.3 contains three columns for calculating current draws. For each column, calculate the current and enter the total (in amperes) in the bottom row. When finished, copy the totals from Calculation Column 2 and Calculation Column 3 to Table 6.4 on page 40.

Table 6.3 System Current Draw Calculations

Device Type	Calculate Column 1 Primary, Non-Fire Alarm Current (amps)			Calculate Column 2 Primary, Fire Alarm Current (amps)			Calculation Column 3 Secondary, Non-Fire Alarm Current (amps)		
	Qty	X (current draw) =	Total	Qty	X (current draw) =	Total	Qty	X (current draw) =	Total
Main Circuit Board	1	X [0.091] =		1	X [0.145] =		1	X [0.065] =	
Power Supervision Relay	[]	X [0.025] =		[]	X [0.025] =		[]	X [0.025] =	
NAC/Output #1				[]	X [] =				
NAC/Output #2				[]	X [] =				
NAC/Output #3				[]	X [] =				
NAC/Output #4				[]	X [] =				
Current Draw from TB4 Terminals 9 & 10		[] =			[] =			[] =	
Sum each column for totals		Primary Non-Alarm =			Primary Alarm =			Secondary Alarm =	

6.4 Calculating the Battery Size

Use Table 6.4 to calculate the total Standby and Alarm load in ampere hours (AH). This total load determines the battery size (in AH) required to support the power supply under the loss of AC power. Complete Table 6.4 as follows:

1. Enter the totals from Table 6.3 on page 39, Calculation Columns 2 and 3 where shown
2. Enter the NFPA Standby and Alarm times. Refer to “NFPA Battery Requirements”
3. Calculate the ampere hours for Standby and Alarm, then sum the Standby and Alarm ampere hours
4. Multiply the sum by the derating factor of 1.2 to calculate the proper battery size (in AH)
5. Write the ampere hour requirements on the Protected Premises label located inside the cabinet door

Table 6.4 Total Secondary Power Requirements at 24 VDC

Secondary Standby Load (total from Table 6.3 Calculation Column 3) []	Required Standby Time (24 or 60 hours) X []	=	AH
Primary Alarm Load (total from Table 6.3 Calculation Column 2) []	Required Alarm Time (for 5 min., enter 0.084, for 10 min., enter 0.168) X []	=	AH
Sum of Standby and Alarm Ampere Hours		=	AH
for nonULC applications, multiply by the Derating Factor ¹		X 1.2	
for ULC applications, multiply by the Derating Factor ¹		X 2.5	
Battery Size, Total Ampere Hours Required		=	AH

Table Footnote

1. Multiply by only one of the Derating Factors, depending on whether the power supply is being used for a ULC (Canadian) application or nonULC application.

6.4.1 NFPA Battery Requirements

NFPA 72 Local and Proprietary Fire Alarm Systems require 24 hours of standby power followed by 5 minutes in alarm

6.4.2 Selecting and Locating Batteries

Select batteries that meet or exceed the total ampere hours calculated in Table 6.4. The power supply can charge batteries in the 7 AH to 18 AH range. The power supply cabinet is capable of housing batteries up to 7 AH. Batteries larger than 7 AH require the BB-17F or other UL listed external battery cabinet.

APPENDIX A Device Compatibility

A.1 System Sensor - 24VDC

Use only 24VDC devices with 24 volt control panels.

MODEL NUMBER & NOMENCLATURE (System Sensor)
CH12/24 Electronic Chime/Sounder
CH2415, CH241575, CH2475, CH24110 SpectrAlert Chime with Strobe
MA-12/24D Electronic Sounder
MA12/24EH Multi Alert Horn with Mechanical Tone
MAEH24LO, MAEH24LOC, MAEH24LOLA, MAEH24M, MAEH24MC, MAEH2415ADA, MAEH2475ADA, MAEH241575ADA, MAEH24110ADA, MAEH2415ADAS, MAEH241575ADAS Multi Alert Horn with Mechanical Tone/Strobe
MASS24D, MASS24LO, MASS24M Electronic Sounder/Strobe
MASS24LOC, MASS24MC Electronic Ceiling Sounder/Strobe
MASS24LOLA Electronic Sounder/Strobe with Fuego lens
MASS2415ADA, MASS2475ADA, MASS24110ADA, MASS241575ADA Sounder/Signaling Strobe
MASS2415ADAS, MASS241575ADAS Sounder/Signaling Strobe w/ Synch. Ckt.
MDL / MDLW Sync Modules for use with SpectraAlert series
P2415, P241575, P2430, P2475, P24110 SpectrAlert Horn/Strobe
PA400R, PA400W , PA400B Sounder
PC24115, PC24177 SpectrAlert Ceiling Mount Horn/Strobe
PS24LO Add-on Strobe
RP2415ADA, RP241575ADA, RP2475ADA, RP24110ADA Retrofit Strobe Plate
S2415, S241575, S2430, S2475, S24110 SpectrAlert Strobe
SC24115, SC24177 SpectrAlert Ceiling Mount Strobe
SP100W24LOC, SP100W24MC Ceiling Speaker/Strobe, 8" round grille
SP101R24LO, SP101R24M Speaker/Strobe, 5" square grille
SP2C24115, SP2C24177 SpectrAlert Ceiling Mount Speaker Strobe
SP2C2415, SP2C2430, SP2C2415/75, SP2C2475, SP2C24110 SpectrAlert Speaker Strobe
S1224MC, P1224MC, SP1224MC SpectrAlert Strobe
SS24, SS24LO, SS24M, Strobe
SSM24-6, SSM24-8, SSM24-10 Alarm Bell
SS24LOC, SS24LOBC(beige), SS24MC Ceiling Strobe
SS2415ADA, SS2475ADA, SS24110ADA, SS241575ADA Signaling Strobe
SS2415ADAS, SS241575ADAS Signaling Strobe with Synch. Circuit
V4R2415ADA, V4R2475ADA, V4R24110ADA, V4R241575ADA Speaker/Signaling Strobe
SPH-15R, SC2415, SC241575, SC2430, SC2475, SC2495, PC2415, PC242575, PC2430, PC2475, PC2495, SP2C2415, SP2C242575, SP2C495

System Sensor SpectrAlert Advance

System Sensor Spectralert Advance chimes, chime strobes, horns, horn strobes and strobes base models: CHR, CHW, CHSR, CHSW, HR, HW, P2R, P2W, P2RH, P2WH, P4R, P4W, P4RH, P4WH, PC2R, PC2W, PC2RH, PC2WH, PC4R, PC4W, PC4RH, PC4WH, SCR, SCW, SCRH, SCWH, SR, SW, SRH, SWH, SW-ALERT, SWH-ALERT, MHR, MHW followed by suffixes denoting application (K=outdoor), market (A=Canada) and / or markings (P=Plain, SP=Spanish, FR=French, B=Bi-lingual and PG=Portugese).

(UL 864 9th Edition)

System Sensor SpectrAlert Advance Speakers

System Sensor Spectralert Advance speakers and speaker strobes base models: SPR, SPW, SPRV, SPWV, SPSR, SPSW, SPSRH, SPSWH, SPSRV, SPSWV, SPCR, SPCW, SPCRV, SPCWV, SPSCR, SPSCW, SPSCRH, SPSCWH, SPSCRV, SPSCWV, SPSCRVH and SPSCWVH followed by suffixes denoting application (K=outdoor), market (A=Canada) and / or markings (P=Plain, SP=Spanish, FR=French, B=Bi-lingual and PG=Portugese).

A.2 Gentex - 24VDC

Use only 24VDC devices with 24 volt control panels.

MODEL NUMBER & NOMENCLATURE (Gentex)
GEC-24-15,GEC-24-30,GEC-24-60,GEC-24-75,GEC-24-110,GEC-24-15/75W Horn/Strobe
GES-24-15, GES-24-30, GES-24-60,GES-24-75,GES-24-110,GES-24-15/75W Strobe
GMH-24 Electro-Mechanical Horn
GMS-24-15, GMS-24-15-1, GMS-24-110, GMS-24-110-1, GMS-24-1575-1, GMS-24-3075, GMS24-30W, GMS24-60W Electro-Mechanical Horn with Strobe
GOT-24 Multi-Tone Horn
GOS-24-15-1, GOS-24-110-1, GOS-24-1575-1, GOS-24-3075-1 Multi-Tone Horn/Strobe
GXS-4RH, GXS-4BH, GXS-4RL, GXS-4BL Strobes
GXS-4-15, GXS-4-15-1, GXS-4-1575, GXS-4-30, GXS-4-60, GXS-4-110, GXS-4-110-1, GXS-4-3075 Strobe
GX-90-4 Horn
GX-90S-4BH, GX-90S-4BL, GX-90S-4RL, GX-90S-4RH, GX-90S-4-15, GX-90S-4-15-1, GX-90S-4-110, GX-90S-4-110-1, GX-90S-4-1575 Horn with Strobe
HG124 Electronic Horn
HS24-15, HS24-15/75, HS24-30, HS24-60, HS24-110, HS24-110W, HS24-75W, HS24-60W, HS24-30W, Multi-Tone Horn/Strobe
SHG-24L, SHG-24H, SHG24-15, SHG24-15-1, SHG 24-60, SHG24-110, SHG24-110-1, SHG24-1575, SHG24-30, SHG24-60, SHG24-3075 Electronic Horn with Strobe
SPK4-15, SPK4-15-1, SPK4-1575, SPK4-110, SPK4-110-1, SPK4-24-3075 Speaker with Strobe
SPK8-15, SPK8-15-1, SPK8-1575, SPK8-110, SPK8-110-1B, SPK8-24-3075 Speaker with Strobe
SPKE4, SPKE4-15-1, SPKE4-15/75, SPKE4-15/75-C SPKE4-30/75, SPKE4-60, SPKE4-110-1, SPKE4-60W, SPKE4-30W Speaker with Strobe
SPKE8, SPKE8-15-1, SPKE8-15/75, SPKE8-15/75-C, SPKE8-30/75, SPKE8-60, SPKE8-110-1, SPKE8-1575W, SPKE8-30W Speaker with Strobe
ST24-15, ST24-15/75, ST24-30, ST24-60, ST24-110, ST24-75W,ST24-110W, ST24-30W Strobe
WGMS-24-75 Weatherproof Electro-Mechanical Horn with Strobe

A.3 Cooper-Wheelock - 24VDC

Use only 24VDC devices with 24 volt control panels.

MODEL NUMBER & NOMENCLATURE (Cooper-Wheelock)
7002T-24 Horn with Strobe
AES-DL1-WM-24-VF-R, AES-EL1-WM-24-VF-R Multi-Tone Signals
AES-DL1-LSM-24, AES-EL1-LSM-24 Horn Strobe
AH-24, AH-24WP Horn
AMT-12/24 Multi-Tone Horn
AMT-24-IS-VFR, AMT-24-LS-VFR, AMT-24-LSM-VFR, AMT-241575-FR Multi-Tone Horn Strobe
AS-2415, AS-2430, AS-2430C , AS-2475, AS-24110, AS-241575 Audible Strobe
AS-2415W, AS-2430W, AS-2475W, AS-24110W, AS-241575W Horn/Strobe
AS-24MCW-FR/ FW , AS-24MCC-FR/FW Multi-Candela Appliance
ASWP-2475W- FR/FW Weatherproof Audible Strobe
CH-CF1-IS-24-CFW, CH-CF1-LS-24-CFW, CH-CF1-MS-24-CFW Chime
CH-DF1-IS-24-VFR, CH-DF1-LS-24-VFR, CH-DF1-LSM-24-VFR, CH-DF1-MS-24-VFR Chime
CH70-24- R/W , CH90-24- R/W Chime
CH70-2415W, CH70-2430, CH70-2475, CH70-241575 Chime with Strobe
CH70-24MCW-FR/ FW Multi-Candela Appliance
CH90-2475C, CH90-24100C Chime with Strobe
DSM-12/24 Dual Synchronization Module
EH-DL1-WM-24-VF-R, EH-EL1-WM-24-VF-R Electronic Horn Strobes
HSW-24-HFR, HSPW-24-HFR, HS2W-HFR Strobe
IS-24-VFR, IS1-24-VFR, IS3-24-VFR Strobe
ISP-24-VFR Strobe
LS-24-VFR, LS1-24-VFR, LS1M-24-VFR LS3-24-VFR, LS3M-24-VFR Strobe
LSM-24-VFR Strobe
LSP-24-HFR, LSPM-24-VFR Strobe
MB-G6-24-R Motor Bell, 6" gong
MB-G10-24-R Motor Bell, 10" gong
MBS-G6-24-R Motor Bell/Strobe, 6" gong
MBS-G10-24-R Motor Bell/Strobe, 10" gong
MIZ-24 Mini Piezo Horn
MIZ-24-HSW-HFR, MIZ-24-IS-VFR, MIZ-24-LS-VFR, MIZ-24-LSM-VFR, MIZ-24-MS-VFR, MIZ-24-WM-VFR, MIZ-TC24-R, MIZ-TC24-W Mini-Horns Strobe
MS-24-VFR, MS1-24-VFR, MS3-24-VFR Strobe
MSP-24-HFR Strobe
MT-12/24-R MultiTone
MT-24-WM, MT-24-WM-VFR MultiTone Strobe 117cd
MT-24-IS-VFR, MT-24-LS-VFR, MT-24-LSM-VFR, MT-24-MS-VFR MultiTone Strobe
MT-24-SL-VFR, MT-24-SLM-VFR Multi-tone/Strobe
MT4-24-IS-VFR, MT4-24-LS-VFR, MT4-24-LSM-VFR, MT4-24-MS-VFR MultiTone Strobe
NS-2415W-FR, NS-2430W-FR, NS-2475W-FR, NS-24110W-FR NS-241575W-FR Horn Strobe
NS4-2415W-FR, NS4-2430W-FR, NS4-2475W-FR, NS4-24110W-FR, NS4-241575W-FR, NS4-24MCW-FR, NS-24MCW-FW, NS-24MCW-FR Horn Strobe
RS-1230, RS-2415, RS-2430, RS-2475, RS-24110, RS-241575 Strobe

MODEL NUMBER & NOMENCLATURE (Cooper-Wheelock)
RS-2415W, RS-241575W Strobe
RSS-2415W, RSS-2415/75W, RSS-2430W, RSS-2475W, RSS-24110W Strobe
RSS-24MCW-FR/FW Strobe
RSS-2415-CR-FW, RSS-2430-CR-FW, RSS-2475-CR-FW, RSS-24100-CR-FW Strobe
RSS-24150-CR-FW, RSS-24177-CR-FW Strobe
RSSP-24MCW-FR/FW strobe
RSSP-2415W, RSSP-2415/75W, RSSP-2430W, RSSP-24185W Strobe
SCM-24-R Synchronized Controller Module
SHW-24-HFR, SH2W-24-HFR, SHPW-24-HFR Strobe
SL-24-VFR, SL1-24-VFR, SL3-24-VFR, SLP-24-VFR Strobe
SLM-24-VFR, SL1M-24-VFR, SL3M-24-VFR, SLPM-24-VFR Strobe
SM-12/24 Synchronization Module
SR-2415, SR-241575 Synchronized Strobe
WMT-24-FR, WM1T-24-FR, WM3T-24-FR Strobes
AS-24MCC-FW, CH90-24-MCC-FW, E90-24MCC-FW, ET90-24MCC-FW, HS-24-R/W,
MIZ-24S-R/W, RSS-24MCC-FW, NH-12/24R/W

A.4 Notification Appliances For Canadian Applications

- Refer to manufacturer's installation instructions for more information.
- Contact manufacturer for current draws or additional options

System Sensor

MDLA / MDLWA Sync Modules, H24A, P1224MCA, P2415A, P241575A, P2475A, P24110A, PC2415A, PC241575A, PC2430A, PC2475A, PC24115A, PC24177AS1224MCA, S2415A, S241575A, S2475A, SC24110A, SC2415A, SC241575A, SC2430A, SC2475A, SC2495A, SC24115A, SC24177A,
SSM24-6A, SSM24-8A, SSM24-10A - Alarm Bells
CHWA, CHRA, HRA, HWA, SRA, SWA, SCRA, SCWA, SRHA, SWHA, SCRHA, SCWHA, P2RA, P2WA, PC2RA, PC2WA, P4RA, P4WA, PC4RA, PC4WA, CHSRA, CHSWA

Gentex

Strobe lights, synchronizable type, Models ST24-15, -15/75, -30, -60, -75, -110; Models GES24-15, -15/75, -30, -60, -75, -110, -177. Models may be followed by suffix -P (plain), followed by W (wall), followed by W or R (white or red color). Intended for indoor use on a wall.

Strobe light, synchronizable type, Model GES3-24, may be followed by suffix -P (plain), followed by W (wall), followed by W or R (white or red color). Selectable candela (15cd, 30cd, 60cd, 75cd and 110cd). Intended for indoor use on a wall only.

Strobe light, synchronizable type, Model GES3-12, may be followed by suffix -P (plain), followed by W (wall), followed by W or R (white or red color). Selectable candela (15cd, 30cd, 60cd, 75cd). Intended for indoor use on a wall only.

Strobe light, synchronizable type, Model GCS24, may be followed by suffix -P (plain), followed by C, followed by W or R (white or red color). Selectable candela (15cd, 30cd, 75cd, 95cd, 115cd and 150cd). Intended for indoor use on a wall or a ceiling.

Sync modules, Models AVS44 and AVSM, may be followed by Suffix W or R (white or red color). Intended for indoor use with Gentex synchronizable strobe lights.

Horns, Models GEH24, GEH12 followed by P, R or W, indoor use only; Models GX91 and GX93 for indoor use.

Horn/strobes*, Models GEC24-15, -15/75, -30, -60, -75, -110, -177 may be followed by P, R or W; HS24-15, -15/75, -30, -60, -75, -110, may be followed by -C or -W (ceiling or wall), -R or -W (red or white), -P (plain) and -Z (synchronized); Model GCC24-C ceiling horn/strobe followed by -R, -W or -P; Model GEC3-24 multi-candella horn strobe, may be followed by -R, -W or -P, intended for indoor use, wall mount

Cooper-Wheelock

AH-24, AH-24WP, AMT-24AMT-2475-FR, AMT-24-LS-VFR, AS-2415C, AS-2415W, AS-2475C, AS-2475W, AS-24100C, AS-24110W, AS-24MCW, HS-24-MCW, HS4-241575W, HS4-24MCW, HS4-24MCWH, MIZ-24, MIZ-24S-R/W, MIZ-TC24, MT-24-R, NS-24MCW-FR, NS4-24MCW-FR, RSS-241575W, RSS-24-2415-CR-FW, RSS-2430-CR-FW, RSS-2475-CR-FW, RSS-24100-CR-FW, RSS-24150-CR-FW, RSS-24177-CR-FW, RSS-24MCC-FR/W, RSS-24MCW-FR/W, RSSP-24MCW-FR/W, RSSP-241575W
--

APPENDIX B Wire Requirements

Connecting external system accessories to the main circuits must be carefully considered to ensure proper operation. It is important to use the correct type of wire, gauge and run length for each circuit. The following table lists NAC wiring requirements for the HPF24S6 & HPF24S8 Field Charger Power Supply.

Table B.1 NAC Wiring Requirements for Power Supply

NAC Load (Amps)	Max. allowable total loop resistance (ohms)	CLASS-B Max. allowable wire pair length (feet)				CLASS-A Max. allowable wire pair length (feet)			
		AWG 12 solid	AWG 14 solid	AWG 16 solid	AWG 18 solid	AWG 12 solid	AWG 14 solid	AWG 16 solid	AWG 18 solid
0.25	12.80	3316	2085	1309	824	1658	1042	654	412
0.5	6.40	1658	1042	654	412	829	521	327	206
0.75	4.27	1105	695	436	275	553	347	218	137
1.0	3.20	829	521	327	206	415	261	164	103
1.25	2.56	663	417	262	165	332	208	131	82
1.5	2.13	553	347	218	137	276	174	109	69
1.75	1.83	474	298	187	118	237	149	93	59
2.0	1.60	415	261	164	103	207	130	82	51
2.25	1.42	368	232	145	92	184	116	73	46
2.5	1.28	332	208	131	82	166	104	65	41
2.75	1.16	301	190	119	75	151	95	59	37
3.0	1.07	276	174	109	69	138	87	55	34

Note: Calculations are based on Direct-Current Resistance data for uncoated copper wire, per National Electrical Code (2005 Edition) Table 8, Conductor Properties.

Index

A

AC

- Loss 8
- Loss Reporting Delay 25

AC fail

- delay 22
- see also AC loss reporting delay 22

AC loss

- reporting delay 22

AC loss reporting

- delay 9

AC power 11

- current 11
- LED 10
- voltage 11

activation

- reverse polarity 8

alarm condition 8

applications 8

Auxiliary Power 9, 12

- current 12
- voltage 12

Auxiliary Power Control

- see also resettable or nonresettable power 23

B

backbox dimensions 15

battery

- capacity 11
- charge current 11
- charger capacity 9
- float charge voltage 11
- fuse F1 11
- lead acid 9, 11
- maximum capacity 9
- see also secondary power 11
- trouble 8

battery/charger trouble LED 10

C

cabinet

- see also backbox 15

capacity

- battery 11

charge current

- maximum 11

charger trouble 8

- LED 10

circuit board

- layout 12

Class A Converter Module 16

- see also ZNAC-4 8

Class B

- see also Style Y 8

Coded Input 10

Coded/Noncoded Input Selection 10

coding

- NAC 8

compatibility

input circuit 8

control circuit 8

- current 11
- see also input circuit 11
- voltage 11

current

- maximum continuous 9
- maximum short term 9
- standby 11
- total continuous 11
- total short term 11

D

Device Compatibility 41

dimensions

- backbox 15

E

ELR

- installation 24
- see also End-of-Line Resistor 24

End-of-Line Resistor

- see also ELR 24

F

faults 24

Features 8

filtered power 8

float charge voltage 11

Form-C

- see also Relay 9

G

Gentex - 24VDC 42

ground fault 8

ground fault detection 9, 10

- Jumper JP1 10

ground fault LED 10

H

HPF24S6 8

HPF24S8 8

I

input

- current 11
- voltage 11

input circuit 8

- activation 8
- compatibility 8
- see also control 11

installation 14

J

JP1 Jumper

- ground fault detection 10

JP2 Jumper

- Coded/Noncoded Input 10

JP3 Jumper

- Coded/Noncoded Input 10

Jumper

- JP1 ground fault detection 9, 10
- JP2 Coded/NonCoded Input 10
- JP3 Coded/Noncoded Input 10

Index

L

LED

- AC power 10
- battery/charger trouble 10
- Charger Trouble 10
- Ground Fault 10
- NAC Trouble 10

LED indicators 10

M

mounting

- see also installation 14

N

NAC

- activation 8
- coding 8
- see also Notification Appliance Circuit 8
- supervision 24

NAC Circuit Wiring 16

NAC output

- see also output circuit 11

NAC style

- see also NFPA Style 8

NAC Trouble LED 10

NACs 9

NEC power-limited wiring requirements 18

NFPA Style

- see also Style 8

nonalarm state 8

Noncoded Input 10

nonresettable power 23

Notification Appliance Circuit

- see also NAC 8

O

output

- circuit types 11
- maximum current 3.0 amps 11

output circuit

- current 11
- maximum current 8
- see also NAC output 11
- Style 11
- voltage rating 11

output power 8

P

Power

- nonresettable 8
- resettable 8

power supply

- board layout drawing 12
- connectors and jumpers 12

power supply requirements 37

powering supply 37

power-limited 8

power-limited wiring 18

R

relay

- trouble 8, 9, 11, 25

reporting delay

- AC loss 25

resettable power 23

S

secondary power

- see also battery 11

Special Application Power

- see also Auxiliary Power 12

specifications 11

Startup Procedure 9

strobe synchronization 9

Style

- see also NFPA Style 8

Style Y

- see also Class B 8

supervision 8

- NAC 24
- trouble 24

synchronization

- ADA compatible 8
- selectable 9

System Sensor - 24VDC 41

T

trouble

- supervision 24

trouble relay 8, 9, 11, 25

- contact rating 11

trouble supervision 8

troubles 24

- power supply 8

W

Wire Requirements 46

wiring 9

- AC power 11
- power-limited 18

Z

ZNAC-4 16

- see also Class A Converter Module 8

Notes

Notes

Limited Warranty

Honeywell International Inc. warrants products manufactured by it to be free from defects in materials and workmanship for eighteen (18) months from the date of manufacture, under normal use and service. Products are date stamped at time of manufacture. The sole and exclusive obligation of **Honeywell International Inc.** is to repair or replace, at its option, free of charge for parts and labor, any part that is defective in materials or workmanship under normal use and service. All returns for credit are subject to inspection and testing at the factory before actual determination is made to allow credit. **Honeywell International Inc.** does not warrant products not manufactured by it, but assigns to the purchaser any warranty extended by the manufacturer of such products. This warranty is void if the product is altered or repaired by anyone other than **Honeywell International Inc.** or as expressly authorized by **Honeywell International Inc.** in writing, or is serviced by anyone other than **Honeywell International Inc.** or its authorized distributors. This warranty is also void if there is a failure to maintain the products and systems in which they operate in a proper and workable manner. In case of defect, secure a Return Material Authorization form from our Return Authorization Department.

This writing constitutes the only warranty made by **Honeywell International Inc.**, with respect to its products. **Honeywell International Inc.**, does not represent that its products will prevent any loss by fire or otherwise, or that its products will in all cases provide the protection for which they are installed or intended. Buyer acknowledges that **Honeywell International Inc.**, is not an insurer and assumes no risk for loss or damages or the cost of any inconvenience, transportation damage, misuse, abuse, accident or similar incident.

HONEYWELL INTERNATIONAL INC. GIVES NO WARRANTY, EXPRESS OR IMPLIED, OF MERCHANTABILITY, FITNESS FOR ANY PARTICULAR PURPOSE, OR OTHERWISE WHICH EXTENDS BEYOND THE DESCRIPTION ON THE FACE HEREOF. UNDER NO CIRCUMSTANCES SHALL HONEYWELL INTERNATIONAL INC. BE LIABLE FOR ANY LOSS OF OR DAMAGE TO PROPERTY, DIRECT, INCIDENTAL OR CONSEQUENTIAL, ARISING OUT OF THE USE OF, OR INABILITY TO USE HONEYWELL INTERNATIONAL INC.'S PRODUCTS. FURTHERMORE, HONEYWELL INTERNATIONAL INC. SHALL NOT BE LIABLE FOR ANY PERSONAL INJURY OR DEATH WHICH MAY ARISE IN THE COURSE OF, OR AS A RESULT OF, PERSONAL, COMMERCIAL OR INDUSTRIAL USE OF ITS PRODUCTS.

This warranty replaces all previous warranties and is the only warranty made by **Honeywell International Inc.** No increase or alteration, written or verbal, of the obligation of this warranty is authorized.

Honeywell

World Headquarters

12 Clintonville Road, Northford, CT 06472-1653 USA
203-484-7161 • Fax 203-484-7118

ISO 9001
CERTIFIED
ENGINEERING & MANUFACTURING